

GigaLog S

Table of Contents

1	Getting started.....	3
2	Hardware.....	4
2.1	Analogue Input Options.....	8
2.2	Sample rates.....	10
2.3	From raw values to Engineering values, Calibration, Output format.....	10
2.4	Alarm.....	11
3	Command mode, Configuration.....	12
3.1	Configuration, Commands.....	13
3.2	Configuration, Rs232 data.....	13
3.3	Configuration, Analogue Inputs.....	13
3.4	Configuration, Disk, Files.....	15
3.5	Communications.....	16
3.6	Macros.....	17
3.7	Configuration, Miscellaneous.....	17
3.8	Conditional Instruction.....	18
3.9	Configuration, Frames.....	18
3.10	Configuration, Counters.....	18
4	GigaTerm.....	20
4.1	Connecting to a local board.....	20
4.2	Connecting to a remote board by TCP/IP.....	20
4.3	Connecting to a remote board by modem.....	20
4.4	GigaTerm as a terminal.....	21
4.5	Inputs.....	22
4.5.1	From raw values to Engineering values, Calibration, Output format.....	23
4.5.2	Display current values of inputs.....	24
4.6	Macros.....	25
4.7	Upload.....	26
4.8	Firmware Download.....	26
4.9	First Help.....	26
5	GigaData.....	27
6	Remote Control.....	28
6.1	GPS.....	32
7	Remote acquisition modules.....	33
8	Graphic Display.....	36
9	Application Notes.....	41
9.1	Memory cards, File lengths, Transfer to the PC.....	41
9.2	Tuning the ADC.....	42
9.3	Calculation from the analogue input raw value.....	44
9.3.1	Virtual input, calculation.....	44
9.3.2	Long time counter.....	44
9.4	Second Disk.....	46
9.5	Temperature Sensor LM60.....	47
9.6	Thermocouples.....	48
9.7	Pt100, Pt1000.....	50
10	Technical Summary.....	52
11	Components placement.....	53
12	Schematics.....	54
13	Older Hardware: GigaLog S 805.....	55

This manual shows how to use the data logger GigaLog S.

The GigaLog board is supplied with a firmware and the GigaTerm PC program to configure the board, to upload recorded data, to download another firmware, and the GigaData PC program, to display the data.

This manual does not show, how to program the GigaLog board in C. Programming your own firmware is only necessary, when the supplied firmware cannot be configured for your special application.

Controlord, 484, avenue des Guiols, 83210 La Farlède, Tél. (0033) 494 487174, www.controlord.fr

Version 1111, November 2011

© Controlord, La Farlede. All rights reserved.

1 Getting started

You need

- A GigaLog board with or without housing
- An unregulated power supply from 6 to 16 V.
- A null modem cable to connect the board to a COM port of your PC (female 2-3, 3-2, 5-5 female) (Manual chapter 4.1)
- Or a standard USB cable (Manual ch 4.1 USB)
- A micro sd memory card
- A PC, running Windows
- The GigaLog package installed on the PC: GigaTerm, GigaData, and this manual

Put the sd memory card into the header.

Power supply, 6 to 16 V DC.

Power on the board.

Use the PC utility GigaTerm to communicate with the board.

Null modem cable from the PC COM port to GigaLog S RS232 port RS0.

GigaTerm: Select the COM port at 115200 baud, click on Open to open the port.

You may also use the USB to connect to the board (chapter 4.1).

Click on  to read the current configuration from the board. The board will now answer:

```
GigaLog S v1012
rs0=c,115200,gigalogrs0.txt,300,0 rs1=c,115200,gigalogrs1.txt,300,0
...
board running
```

Stop the running board (ch 3.1). Format the sd memory card using the "fo" command (ch 3.4)

```
st
ok
fo
format
ok
```

This will take some seconds. The red led is on, when the board accesses the memory card.

Display all inputs.

```
a
a00: 8022881 1249.698mV a01: 6688844 1041.900mV a02: 5795473 902.742mV a03: 5126645 798.561mV
a04: 4589396 714.876mV a05: 4143864 645.476mV a06: 3751096 584.296mV a07: 3392776 528.482mV
a08: 2448474 381.391mV a09: 2448496 381.394mV a10: 2448487 381.393mV a11: 2448483 381.392mV
a12: 2448851 381.450mV a13: 2448510 381.397mV a14: 2448850 381.450mV a15: 2448694 381.425mV
```

Set sampling rate to 1 second. (3.3). Inputs a0 and a1 are already declared as analogue inputs. Start the board.

```
ad=1s
ok
go
resume
```

The board now starts sampling data. Wait some seconds. Stop the board again. List the files on the sd memory card.

```
st
ok
ls
gigalog adc          352
```

Send "up gigalog.adc" to the board, to display the stored data.

```
up gigalog.adc
>2008:07:03 11:51:24 8023865 6689862
>2008:07:03 11:51:25 8023872 6689896
>2008:07:03 11:51:26 8023899 6689875
>2008:07:03 11:51:27 8023892 6689860
EOF
```

Or use GigaTerm, tab Upload, to load the data into a file on the PC.

You may then click on the button "GigaData gigalog.adc", to start GigaData, and display the data.

2 Hardware

Power supply

Power supply recommendations.

	Voltage	Current	
Gigalog S	6-16 V	100 mA	
Gigalog S + Graphic LCD	12 V \pm 5%	500 mA	close jumper VLCD
Gigalog S + Gsm65	7- 16 V	1000 mA	
Gigalog S + Graphic LCD + Gsm65	12 V \pm 5%	1500 mA	close jumper VLCD

SD card disk handling

The board accepts FAT16 and FAT32 file systems.

The configuration format command can be used to format the sd card. (config: fo)

When the LED on the board is on, the board is writing to the memory card.

Do not take off the card. Taking off the memory card may destroy the file system on it.

Display

A liquid crystal display, 2 lines x 16 characters, displays the state of the board.

The display shows the actual values of the inputs, independent of the storage of data. Use configuration command a= to change the name, the time, and the format to display for each channel.

The 2x16 display can be replaced by a 4x16 display, or by a 320x240 graphical colour display with touchscreen.

LED

The LED on the board signals:

- Flashing each second: Board is ready to work
- On: Writing to disk. Do not take off the memory card. Taking off the memory card may destroy the file system on it.
- Flashing once all 10 seconds: Low power mode.

Rs232 interfaces RS0 and RS1

SubD 9 pole male communication port

1		
2	RxD	to GigaLog, data, and for configuration
3	TxD	from GigaLog for configuration
4		
5	GND	Common
6		
7		
8		
9		

The 2 serial ports RS0 and RS1 are configured at 115200 baud from the factory, and will accept commands as input.

Both ports can be configured, to store incoming data on a file on the memory card.

Rs485 interface RS2

RS2 is physical a Rs485 port using the 2 screw terminals Dat+ and Dat-. Logical the port works like RS0 and RS1.

Incoming serial data: Rs232 and Rs485

Data is 8 bits, no parity. Baud rates can be 300, 600, 1200, 2400, 4800, 9600, 19200, 28800, 38400, 57600 115200

Baud rates are derived from a 48 MHz frequency.

USB

When connecting the board the first time to an USB port of your PC, Windows detects a new peripheral. The board uses a standard Windows driver. Nevertheless Windows may ask for the driver. Direct Windows to the usb driver directory in the installed software, like "/Program Files/gigalog/usbdriver". Windows treats the USB port as a COM port and gives it a free number.

Speed considerations

GigaLog is designed to store all analogue inputs at 100 Hz (10 ms).

If using higher rates or storing data from Rs232 at the same time, you must verify that the board and the memory card are able to do so.

STOP

Digital input Stop can be used to enable sampling.

Stop is open collector. Tie Stop to 0V to disable sampling. The run/stop switch on the box panel is tied to Stop.

The "Stop" and "Go" command also disable, enable sampling.

The graphical LCD has a STOP/GO switch on the head line left.

When stopped, the board will not execute scheduled macros.

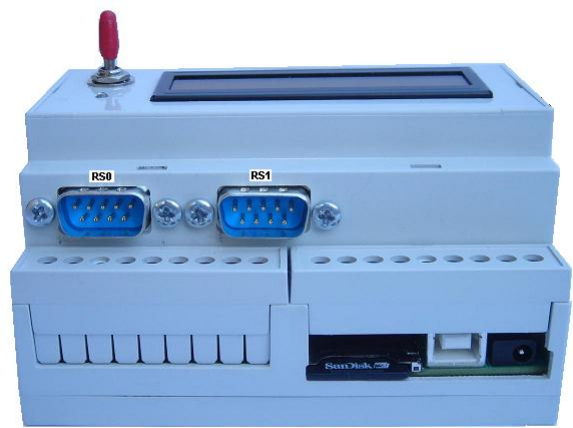
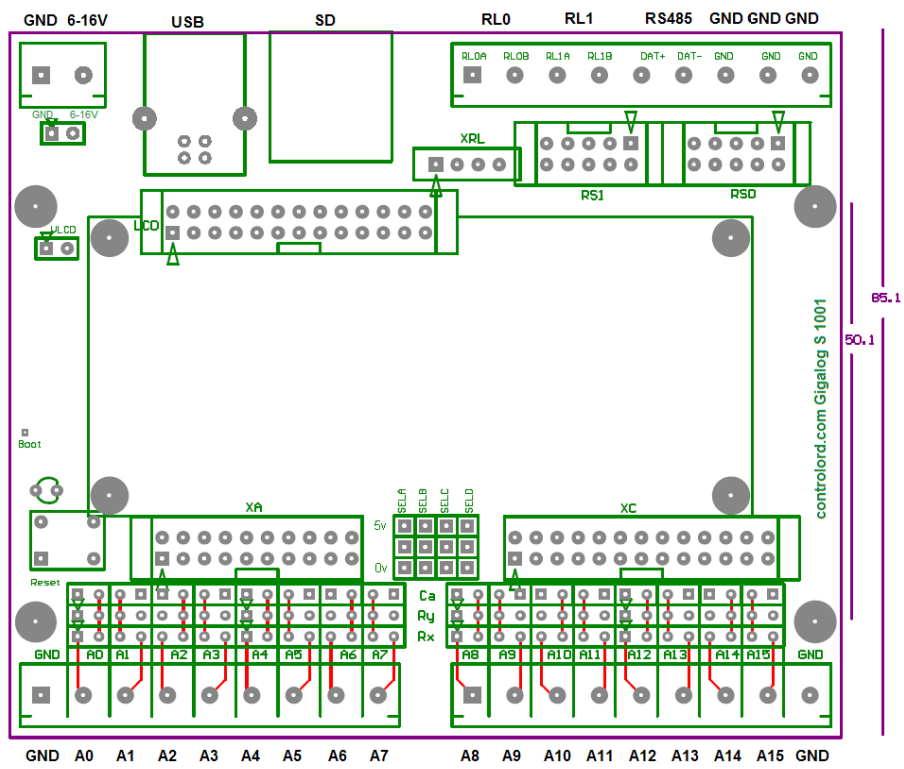

XA: The analogue inputs are also available on an IDC header for flat cable.

	2	4	6	8	10	12	14	16	18	20
	AVCC	A1	A3	A5	A7	A9	A11	A13	A15	AREF
	AGND	A0	A2	A4	A6	A8	A10	A12	A14	AGND
	1	3	5	7	9	11	13	15	17	19

XC: Additional signals are available on an IDC header for flat cable.

	2	4	6	8	10	12	14	16	18	20	22	24	26
VCC	VCA	PA4	PA11 TWCK(I2C)	PA19 RX(CAN)	PA21 TF(SSC)	PA23 MOSI(SPI) TD(SSC)	PB28 AD1 PWM1 TIOB2	PB30 AD3 PWM3 PCK2	AD6	DACA*	DACC*	DACD*	
GND	PA2 16 mA	PA3 16 mA	PA10 TWD (I2C)	PA15 TCLK2	PA20 TX(CAN)	PA22 SCLK(SPI) TK(SSC)	PA24 MISO(SPI)	PB29 AD2 PWM2 PCK1	AD5	AD7	DACB*	GND	
	1	3	5	7	9	11	13	15	17	19	21	23	25

Analogue Inputs

Gigalog S has 16 analogue inputs in single ended mode with reference to GND.

Pairs of inputs (a0-a1, a2-a3,...,a14-15) can be used in differential mode

The Adc is a Texas Instrument ADS1258 in delta-sigma technology.

The analogue signals pass by an integrated multiplexer with an 80-Ohm resistance.

Inputs have an impedance of > 10 M Ohm.

The ADC has a resolution of signed 24 bits.

Each input can be from -100 to +1300 mV.

The voltage reference AREF is a LM4041-AIM3-1.2 1225 mV ± 1.2 mV at 25°C and ± 10 mV at 0..70°C.

Typical resolution of the ADC for a perfectly stable input signal

Storage sample rate	Rresolution in bits
< 10 ms	16
> 10ms, < 100 ms	18
> 100 ms	19

When used as digital input: A logical 0 is 0 to 0.8 V. A logical 1 is 1.2V to 3V. An open input is undefined.

ADC -> voltage

$$U = \text{ADC} * 1225 / 0x780000 = \text{ADC} * 0.1557668 \mu\text{V}$$

Voltage -> ADC:

$$\text{ADC} = U(\text{mV}) * 6419.85$$

2.1 Analogue Input Options

GigaTerm helps you to configure the inputs. Choose an input, choose the input type.

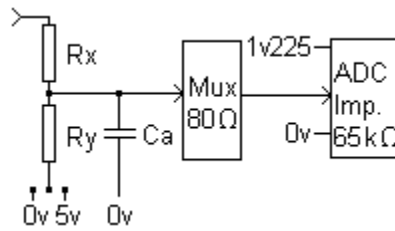

	Input type		$V_i \rightarrow V_{adc}$	$R_x \Omega$	$R_y \Omega$	Ca	Select	
a	Direct voltage -0.1 .. 1.2 V			0	-			
a1	Direct voltage -0.1 .. 1,2 V with protection			1k	-			
a2	Direct voltage -0.1 .. 1,2 V with RC filter			1k		220nF		$1/(6.28 * R * c)$
a3	50 Hz			10k		330nF		
a4	Higher voltages			10k	2k2		0V	$V_o = V_i * R_y / (R_x + R_y)$ $V_i = V_o * (R_x + R_y) / R_y$ $V_o > -100 \text{ mV}$ $V_o < 1.25 \text{ V}$
a5	-0.5 .. 6.5 V			10k	1k			
a6	-1 .. 13 V			33k	1k			
a7	-3.4 .. 41 V			100k	1k			
a8	-10 .. 123 V			220k	1k			
a9	-22 .. 270 V			330k	1k			
a11	Negativ + Positiv voltage			1k	4k7	1k Ω	5V	
a12	-1 .. +1 v			22k	10k	1k Ω		
a13	Differential Inputs			10k		100n		
a14	-1.2 .. +1.2 V			(x 2)		(x 2)		
a10	Differential Inputs			10k	2k2	100n		
a10	Current			0	47		0V	$V_o = I_i * R_y$ $I_i = V_o / R_y$
k	Small voltage	Thermocouple		0	-			$V_o = V_i$
p	Resistance			0	1k		5v	
p1	Pt100			0	10k			
d	Digital input			0	-			
d1	Digital input with pullup			0	10 k		5v	
d2	Digital input, higher voltage			D	10 k		5v	

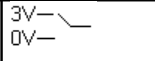
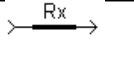
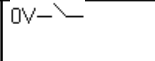
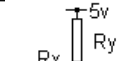
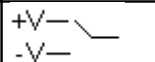
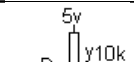
c	Counter			0	-			
c1	Counter with pullup			0	10 k		5v	
c2	Counter, higher voltage			D	10 k		5v	

2.2 Sample rates

Sample rates can be from 1 millisecond to 24 hours.
 The ADC sample rate is higher than the storage sample rate.
 GigaLog stores the average sum of the last period in the disk file.
 (GigaLog can also store the minimum and maximum values of the last period)
 The output of the ADC is signed 24 bits.
 The average sum will be calculated in a 32 bit float.

Storage sample rate on disk Examples	Proposed ADC sample rate for average sum
1 ms	1 ms
100 ms	1 ms
1 s	5 ms
1 m	300 ms
1 h	18 s
24 h	432 s

2.3 From raw values to Engineering values, Calibration, Output format

The raw value is at the output of the ADC.. The real value is the value stored on the disk. You can specify for each analogue input an expression to calculate a real value from the raw value.
 This expression is also used, to calibrate an input.
 For example

$$a3 = a * 7 + 200, 2$$

For a raw value of 0, the real value on the disk is $0 * 7 + 200 / 100 = 2.00$. For a raw value of 35, the value is $35 * 7 + 200 / 100 = 4.45$
 The multiplier, and the term are 32 bit float.
 The expression also gives the output format

Expression	Raw value	Real value
a	24002	24002
a*0.002,0	24002	48
a*2,3	24002	48.002

GigaTerm software helps you to find the expression.

2.4 Alarm

Each input can be configured to trigger an alarm.

You may configure for each input a minimum threshold, and a maximum threshold(configuration a)

You may set for all inputs an alarm filter delay et0, and an alarm redo delay et1(configuration et)

The alarm is calculated on data directly from the inputs, not on the data stored on the memory card.

There may thus be slight differences.

Analogue inputs

Compare the raw value to the thresholds.

When the raw value is less than the min threshold, trigger alarm.

When the max threshold is not equal 0, and the raw value is greater than the max threshold, trigger alarm.

Digital inputs

Compare the input to the thresholds.

When the min threshold is not equal 0, and the input is 0, trigger alarm.

When the max threshold is not equal 0, and the input is 1, trigger alarm.

Counters

Compare the counter to the thresholds.

When the max threshold is not equal 0, and the counter is greater than the max threshold, trigger alarm.

When storing the counter to the disk, the counter is less than the min threshold, trigger alarm.

Thermocouples, Pt100

Compare temperature to the thresholds.

When the min threshold is not equal 0, and the temperature is less than the min threshold, trigger alarm.

When the max threshold is not equal 0, and the temperature is greater than the max threshold, trigger alarm.

Thermocouple temperatures are in 0.01°C (7700= 77°C) , Pt100 in 0.1°C (770= 77°C).

When an alarm is active for a period of et0, macro 1 will be executed.

When the alarm does not disappear within et1, macro 1 will be executed again.

When the alarm disappears for et0, macro 2 will be executed.

Et0, and et1 are in multiples of .1 seconds, i.e. 10 represent 1 second.

Examples for macro 1

fa alarm.log %d Alarm; rI0=1	Write into a file on the memory card: date and time, Alarm; switch relay 0
ph 0603154848 ; ec %d Alarm ; a; hu	Call center, using a modem, echo date, "Alarm", dump all inputs, hang up the phone
sm 0603154848; ec Alarm; a0; a1; sn	Send SMS, using a GSM modem, send "Alarm", dump inputs a0, and a1

Example for macro 2

rI0=0	Switch relay 0
-------	----------------

3 Command mode, Configuration

How to enter Configuration, Command mode

Use the PC utility GigaTerm to communicate with the board.

You may use the USB port, the RS232 port RS0, or RS1, or the Rs485 port RS2.

The USB port is always in command mode.

You can not use a serial port RS232, or Rs485, that has been configured to store incoming data to the memory card.

If you use a RS232 port, you need a null modem cable (female 2-3, 3-2, 5-5 female) to connect the board to the PC.

Select a COM port at 115200 baud, click on Open to open the port.

To work remote with a modem, see chapter GigaTerm.

Click on  to read the current configuration from the board. The board will now answer:

GigaLog S v1012

...

V1012 Indicates the version of the board software: December 2010.

Click on the "Terminal" tab to send commands to the board in this window.

Click on the "Configuration" tab do display the current configuration.

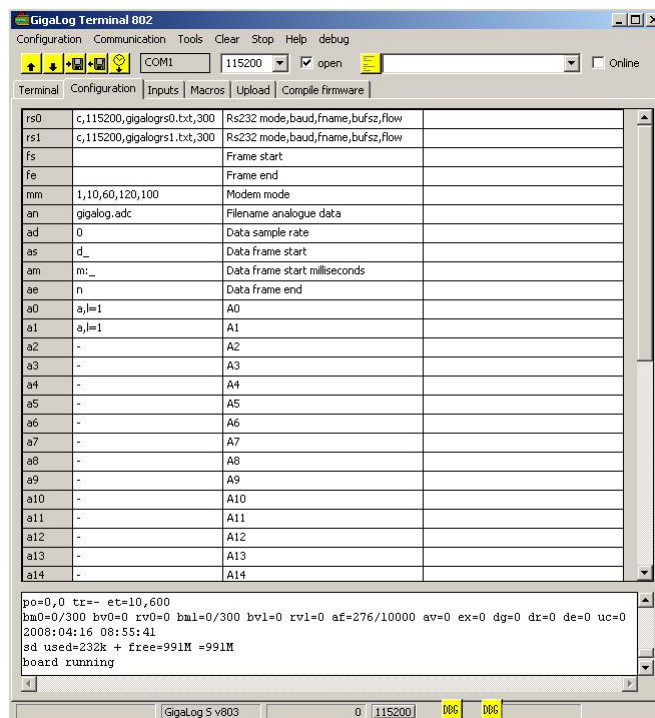

You may now edit the settings.

Click on Configuration -> Download to Board to send the configuration to the board.

A command line is limited to 80 characters, it ends with a <cr> carriage return or a <lf> line feed.

It may contain several commands, separated by ';' or by ' '.

3.1 Configuration, Commands

d
Display configuration

Z
Zero: get back factory standard, clears all configuration values.

zc
Zero counters bm..

st
Stop log mode. This command is like switching the STOP switch to Stop.

go
Start log mode. This command is like switching the STOP switch to Go.

3.2 Configuration, Rs232 data

rs[0|1|2]=[-|c|m|i|s],<baud>,<filename>,<buffer size>,<flow control>
Configuration of RS0, RS1, and RS2

c : Port in command mode.

m: Ignore command line, that look like messages from a modem

i: Ignore all errors in command lines

d: Log incoming Rs232 data to a file on the memory card.

s: Remote Acquisition Slave: Only accepts # commands.

<baud> Baud rate.

<filename> File name for mode 'd'. The name may include special characters, see command an=.

<buffer size> for incoming data

fs=<frame>
Frame start. See frame.

fe=<frame>
Frame end. See frame.

3.3 Configuration, Analogue Inputs

an= <path>
Name of the file on the disk for analogue data.
The name is limited to 30 characters. It may include directories: [/][<dir>]*<name>
Sequences of %<character> will be replaced in the name:

%M month by yyyyMM

%d date by yyyyMMdd

%h hour by hh

%m minute by hhmm

%s second by hhmmss

When the name of the file changes, the file will be closed, another will be opened.

For example:

an=adc%d%m.adc: Data will be stored in one file per minute

an=d%d/a%d%m.adc: Data will be stored in one file per minute, in one directory per day.

ad= <storage rate>[,<ADC rate>]
Analogue data storage, and ADC sample rate. Sample rate will be ignored in low power mode.
When missing, the ADC sample rate will be calculated from the storage rate

0 no samples

1ms .. in milliseconds

1s ... in seconds

1m ... in minutes,

1h ... in hours

as= <frame>
Frame start each second, minute, or hour. See Frame.

am= <frame>

Frame start each millesecond, See Frame.

ae= <frame>

Frame end. See Frame.

a<ch>=[-|d|c|a|k|p|z][<term>][*<m>][+<p>][,<c>][<<min>][><max>][,n=<name>][,d=<diff>][,p=<reference>][!<lcd>][m=[a][m][M]]

Configuration of an input

- not used, input will be sampled
- d as digital input
- c as counter
- a as analogue input
- k thermocouple type K
- p Pt100
- z No sampling

Values *m+p,c: see analogue inputs calculation. Determines also the output format.

<term> Number for gigaterm to select input option

<min> and <max> for alarm. See alarm.

<name> for LCD

<diff> 0 single ended, 1 differential, only on inputs 0,2,4,...,14.

<reference> Reference input number. Subtract the reference input from the input (real values)

<lcd> alpha LCD: 1..99: time to display channel on LCD in seconds. 999: do not display.

Graphic LCD: swcc: s=style (0..2), w=width(0..9) cc=color (00..15)

m=[a][m][M]: Store average(a), minimum(m), maximum(M) value. Stores up to 3 values per input.

a<ch>=v[*<m>][+<p>][,<c>][,c=<expr>][,n=<name>][!<lcd>]

Declaration of a virtual input, calculated from other inputs by expression.

Expression is a sequence of up to 5 elements, connected by +, -, *, or /.

Elements are inputs or small constants (0..99).

Example: c=a0-a1*a2

Calculation will be done on the calculated real values of the inputs, strictly from left to right.

The value of a counter is the count of the last full period, as defined by ad.

A virtual input can not trigger an alarm.

See chapter: Calculation from the analogue input raw value

a<ch>=vc[*<m>][+<p>][,<c>][,c=<expr>][,n=<name>][!<lcd>]

Declaration of a long time counter, calculated from other inputs.

See chapter: Calculation from the analogue input raw value

a<ch>=vp[*<m>][+<p>][,<c>][,n=<name>][!<lcd>]

Declaration of a personal input. Personal firmware addition.

a[<ch>] [<n>,<r>]

Dump input <ch> or all analogue inputs n times, speed <r> ms.

ar[<ch>] [<filter>,<series>]

Calculate input resolution of one or all inputs, digital filter, series of tests.

Digital filter is 10 minimum, except for samples faster than 10 ms. Series needs space in memory, should be 100.

av[<ch>]= <n>

The av command changes long time counters

av= z clears all counters

av<ch>= <n> sets a single counter.

av<ch>+= <n> increments a single counter.

ax=<adc config>,<buffer size>,<m samples>

<adc config> cbdr c=chopping, b=bias, d=delay, r=data rate. See doc ADC ADS1258

<buffer size>: Size of analogue data buffer from acquisition to write to disk.

<m samples>: Number of samples analogue inputs for display data, not for the data on the memory card.

et=<et0>,<et1>

Alarm filter delay et0, and alarm redo delay et1. In multiples of .1 s. See Alarm.

po=<threshold low>,<threshold high>

Power supply monitoring. Values are in mV.

When the power falls under threshold high, stop storing data to disk, synchronize the internal buffers with the disk. When the power falls under threshold low, stop all disk activities. When power comes back over threshold high, return to normal work, only some data may be lost.

tr=[+|-|i+|i-|i]<channel>,<threshold low>,<threshold high>[,<prologue>,<epilogue>[,<filter>]]

Sample analogue data to disk only, when trigger is active.

+: Positive, - negative level activates. Channel is an analogue input from 0 to 15.

Case +: When the input rises over the threshold high, start sample data to disk.

When the input falls under the threshold low, stop sample to disk.

Prologue is a number of probes to be held in memory, and to be stored, when the trigger gets valid.

This number is limited by an internal buffer, see Configuration ax <buffer size>, Counters: af, av.

Epilogue gives a number of probes to be stored after the trigger got invalid.

Filter is the minimum time in milliseconds a threshold must be passed.

tr i+ like tr +, but only a one shot sample, when reaching the threshold, including prologue, and epilogue.

tr i- like tr -, tr i on both edges.

tr -t sends a one shot trigger, when the trigger is defined and inactive. Samples prologue and epilogue.

Thresholds are in millivolt.

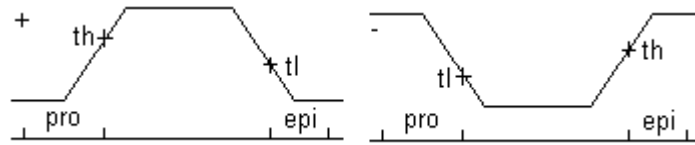

3.4 Configuration, Disk, Files

<path>= [<drive>][<dirname>/*<filename>

<drive>= c: sd-card on board

<drive>= d: sd-card external

fo [<drive>][<volumename>]

Format disk

ls [<path>]

Display the files in the directory

fa <path> <text>

If the file does not exist, create the file. Append a line containing the text to the file. The text may include spaces. A ';' indicates the end of the command.

Replacements in the text: %<n>[-<m>]: Analogue input n [to m], %*: all declared inputs, %d: Date and time, %m: like %d with millisecond, %g: GPS position, %n no newline at the end of the line.

cp <path> <path>

Copy the file 1.path to 2.path

mv <path> <path>

Rename the file 1.path to 2.path

cmp <path> <path>

Compare the files

rm <path>[, <path>]

Remove the file or the files from the disk.

md <filename>

Make dir.

cd <filename>

Change dir.

up [-b|-c] <path> [-<off>] [<start>]

upload file.

The command up gigalog.adc uploads the complete file.

Up gigalog.adc 2004:09:09 12:30:03 uploads only data stored after this date.

Up gigalog.adc -1000 starts at offset 1000

Up -b sends binary data in hexadecimal format.

Up -c starts reading data at the file offset uc, sends a start line to switch GigaTerm to receive data, and at the end stores the new file offset in uc. This version can be used from a macro to upload data.

Each uploaded line is preceded by a ">".

uc=<n>

Set the file offset for the up -c command.

fd <filename>|+<hex data>|!<crc>

File download to disk

dx=<files>,<cache buffers>,<retry>|<sd2>|<vdrive>

<files> Number of files the program can open at a time

<cache buffers> Number of sectors in the buffer cache

<retry> 1: no read after write

<sd2> 4: 2. sd-card

<vdrive> 6: Vdrive

3.5 Communications

ec[0|1|2|3|4] <text>

Echo text to RS0, RS1, RS2, 3=USB, or 4=graphic terminal. Ec without target channel goes back to the sender.

The text may include spaces. A ';' indicates the end of the command.

Replacements in the text: %<n>[-<m>]: Analogue input n [to m], %*: all declared inputs, %d: Date and time, %m: like %d with millisecond, %g: GPS position, %n no newline at the end of the line.

lc <text>

Display text on the alphanumeric LCD display, 2. line.

The text may include spaces. A ';' indicates the end of the command.

For graphical LCD, see command grw.

lm <mode>,<contrast>

LCD display mode: 0: LCD alphanumeric 2 lines x 16 characters, 4: 4 lines x 16 characters.

Other values, see chapter Graphic Display

mm=<log>,<timeout cmd>,<timeout connect>,<timeout disconnect>,<timeout ftp command>

Modem modus. <log>=<logRs0>+<logFile>

<logFile> = 1: log to file modem.log on the memory card.

<logFile> = 2: log to file dialog with modem (RS1)

<logFile> = 3: log to file additional information

<logRs0> = 10: log to Rs0

<logRs0> = 20: log to Rs0 dialog with modem (RS1)

<logRs0> = 30: log to Rs0 additional information

mm Display GSM network state.

mminit Reinitialise Modem.

mmoff Cut power supply modem and graphic display, VMOD, VLCD.

mmon Establish power supply modem and graphic display, VMOD, VLCD.

See commands groff, gron chapter Graphic Display

mmq Display modem server command queue.

tm [0|1|2|3].c]

Enter transparent mode to RS0, RS1, RS2, or USB.

Useful to configure the modem, or a remote acquisition module.

C add CRC to each line for remote acquisition modules.

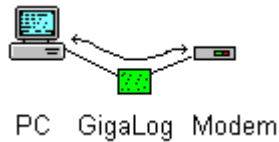

sm See chapter Remote Control
 gf See chapter Remote Control
 gp See chapter GPS
 tz See chapter GPS

3.6 Macros

m<n>=<stime>,<rtime>,<text>

Declare macro <n>

Stime is the time, the macro shall be executed the first time, in seconds from 1.1.2000.

Rtime is the time, the macro when the macro shall be rescheduled after execution, in seconds.

Text is the command line of the macro. The text goes to the end of the line, including ' ', and ' '.

Macros will only be executed in GO mode.

Mx<n> [<time>]

Schedule macro n in time seconds for execution.

3.7 Configuration, Miscellaneous

bn=<name>

Set the name of the board. This name will be displayed on the LCD and in the configuration.

of= <dec. point><separator>

Output format. 1. character is the decimal point in analogue data.

2. character separates inputs in the analogue data file

Default: of=._ (_ = horizontal tab)

CSV Format: of=,_ as=d, am=m:,

lp=<mode>,<uptime>

Low power mode, when <mode>=1

Uptime in ms is the wake up time from power up before executing commands.

The board enters low power mode when

- it is in go mode, and
- there is no macro running, and
- there is no activity on the modem

In power down mode, the board

- flashes the led all 10 seconds
- does not sample data. Storage rate is equal to sample rate (s. command ad).
- does not accept commands from any serial port

The board does not enter power down mode, or leave power down mode, when

- it has to sample, and store analogue data, see ad command storage rate, or
- there is a macro to be executed, or
- the stop switch is on

dt=yymmdd

Set date

ti

Reset/Start timer

ti=hhmm[ss]

Set time

rtc

Read date and time from the real time clock.

The software reads date and time once after reset from the real time clock. Since the internal clock on the micro controller may vary from the real time, it may be useful, to reread the time. Executing this command may have an impact on the stored data and on the execution of macros, since the time may jump forward or backward for some seconds.

t
Display board temperature in °C, and supply voltage.

rl<number>=0|1
Set relay <number> to state 0 or 1. The relay is open in state 0, closed in state 1.

xc<number>=0|1|z
Set pin <number> on the XC header to 0, to 1, or to input.

dc<n>=<value>
Send value to digital to analogue converter.

wt <n>ms|<n>s
Wait <n> milli seconds or <n> seconds.

dl
Enter software download to download new firmware.

Commands sm, gf*: See chapter Remote control
Commands gp, tz: See chapter GPS
Commands rq, rqz, #nn: See chapter Remote Acquisition Modules
Commands gr*: See chapter Graphic Display

3.8 Conditional Instruction

if <primary> =|=|=|>|=|<|<= <primary> <>true commands> [else <>false commands>]
When the condition is true, execute the true commands, else the false commands, if they exist.
Primary:

a<n> Analogue input, real value,
xc<n> input XC header,
t board temperature in °C
v board voltage in mV,
constant.

Example: Macro each second: if a7<300 r10=1 else r10=0

3.9 Configuration, Frames

frame start, frame end, analogue start, analogue millisecond start, analogue end are up to 10 character long fields.
Each character represents

d timestamp yyyy:mm:dd hh:mm[:ss[:uuu]]
u timestamp mm/dd/yyyy hh:mm[:ss[:uuu]] compatible xel US
e timestamp dd/mm/yyyy hh:mm[:ss[:uuu]] compatible xel Europe
t timestamp hh:mm[:ss[:uuu]]
m timestamp milliseconds uuu
- space
_ horizontal tab
n carriage return <cr>, new line <n>
T board temperature,
v board supply voltage
g GPS position
any other output directly

Ex. "fs=d_" "fe=n" will precede each frame with a timestamp, and a tab, and add a <cr><n> at its end.

Ex. "fs=dn" "fe=dn" adds a timestamp line before and after the frame.

Ex. "as=d_" "am=m:_" precedes analogue data with a full date, when the second changed, else only with the new microsecond.

This is compatible with the GigaData program.

3.10 Configuration, Counters

bm0,bm1,bm2 Max size, Rs232/Rs485 buffer was filled with incoming data, should not approach the total buffer size.
bv0,bv1,bv2 Rs232/Rs485 data buffer overflow counter

rv0,rv1,rv2	Receiver overflow counter
af	Max size, analogue data buffer was filled with incoming data, should not approach the total buffer size.
av	Analogue data buffer overflow counter
ex	Exceptions, Alarm counter
dr	Disk compare after read or write error. Retry
de	Disk error.

4 GigaTerm

GigaTerm is a Hyperterminal like program to communicate with the board. Use Gigaterm to communicate with the board, to keep configurations in files, to configure the board, to upload stored data.

You may ask GigaTerm to write the dialogue with the board into a file GigaTerm.log (Tools, Log).

4.1 Connecting to a local board

Use the PC utility GigaTerm to communicate with the board.

You may use the USB port, the RS232 port RS0 or RS1.

The USB port is always in command mode.

You can not use a RS232 port, that has been configured to store incoming data to the memory card.

If you use a RS232 port, you need a null modem cable (female 2-3, 3-2, 5-5 female) to connect the board to the PC.

Select a COM port at 115200 baud, click on Open to open the port.

Click on  to read the current configuration from the board.

USB

When connecting the board the first time to an USB port of your PC, Windows detects a new peripheral. The board uses a standard Windows driver. Nevertheless Windows may ask for the driver. Direct Windows to the usb driver directory in the installed software, like "/Program Files/gigalog/usbdriver". Windows treats the USB port as a COM port and gives it a free number.

4.2 Connecting to a remote board by TCP/IP

Select TCP/IP as Port. Enter the IP number and the port as address: "123.45.67.89 1024"

Open the port. It may take several seconds to establish a connection.

4.3 Connecting to a remote board by modem

See chapter Remote Control, how to configure the local and the remote modem.

Connect the local COM port of the PC to the local modem.

You need a direct modem cable (female 2-2, 3-3, 5-5 male)

Select 9600 baud. Open the port. You are now connected to the local modem.

To verify this, you may enter "ati" <return>. The modem shall answer with an identification message and "OK".

To call the remote board, you need a phone number. You may enter this number by hand, or select it from a phonebook.

 Click on this button, to edit the phone book.

Click "online" to connect to the remote modem and thus to the remote board.

The status field on the bottom left displays "Calling..", the Online check box is greyed.

Wait until the modem signals a connection, the status field displays "Online", and the Online box is checked.

Click on  . The board shall now display its current configuration, that will appear in the terminal window.

To disconnect, click on Online, to disconnect the line, and then on Open, to close the port.

4.4 GigaTerm as a terminal

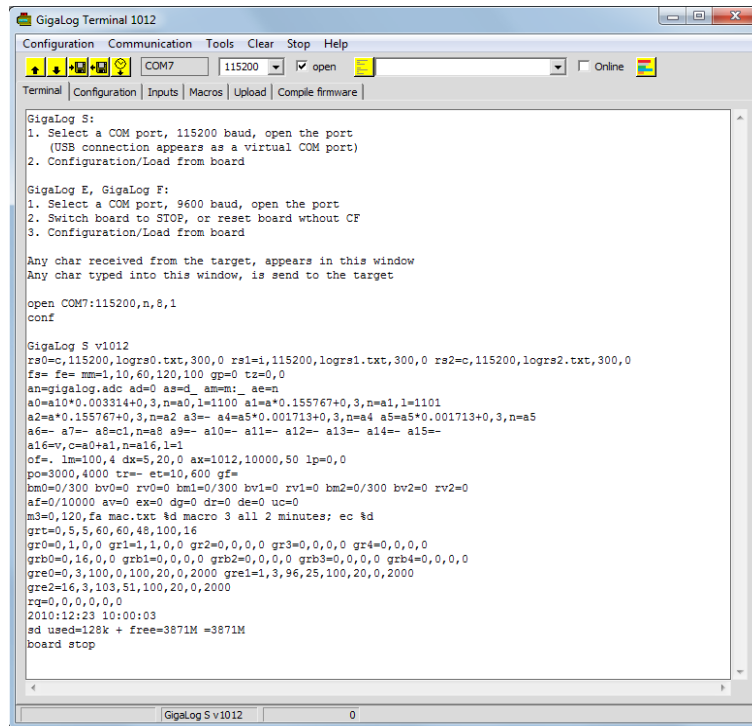

GigaTerm works as a terminal program.

Any character typed into this window, will be send to the board.

Any character received from the board, will be displayed in this window.

You may ask GigaTerm to write the dialogue with the board into a file GigaTerm.log (Tools, Log).

4.5 Inputs

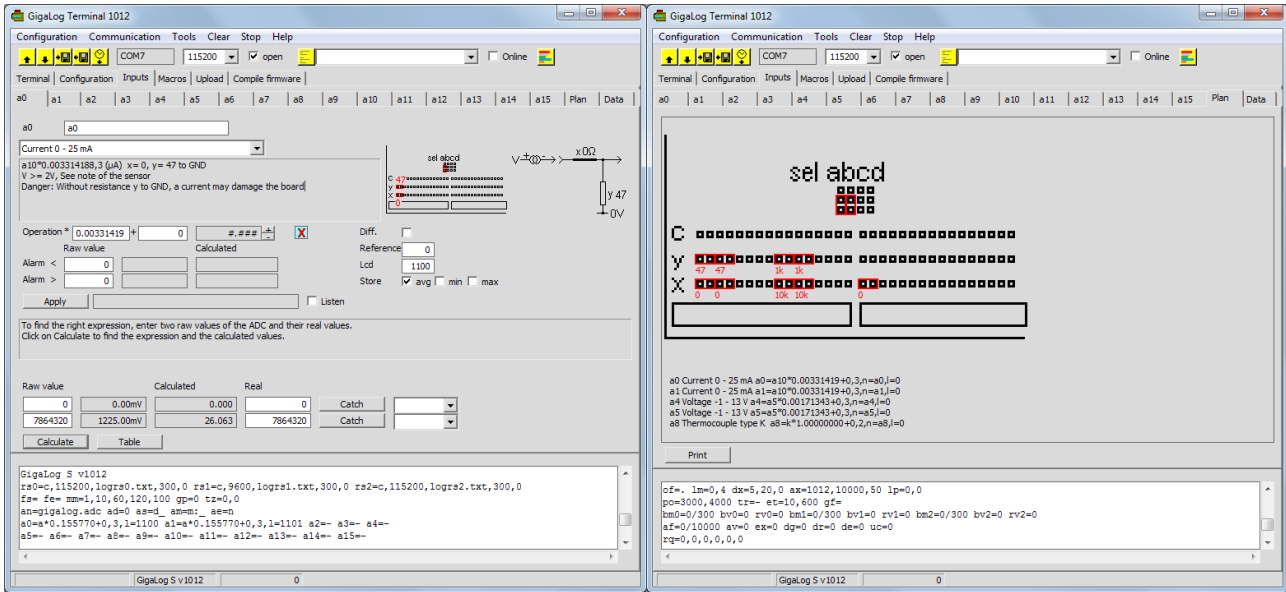

Click on the tab **Inputs**, and then on the tab of an input. Fields in this tab will be shown according to the target board, firmware version, and the selected input type.

Select the input type. You see the jumpers and components to put on the board at the right. Click on **Plan** to see the components for all inputs.

Calculation: Calculates the real value. See below.

Alarm <: if non zero, if the value is lower than this limit, an alarm occurs.

Alarm >: if not zero, if the value is higher than this limit, an alarm occurs.

Diff.: Single ended input or differential. Default: single ended.

Reference: reference input. Default: none.

LCD: display mode for LCD or graphic LCD. See configuration, analogue inputs, a= option I=.

Store: average, minimal, maximal value. Default: only average value.

Apply: Send the configuration of this input to the board.

Listen: Check this box, to request each second the input state from the board.

The real value, that will be logged into the disk file, can be calculated from the raw value at the output of the ADC by a linear equation.

To find this linear equation, you have to enter two raw values of the ADC (X_0 , and X_1) and their corresponding real values (Y_0 , and Y_1).

Catch: Copy a listened line or directly from the input into this line.

Calculate: Calculate the operands from the given raw and real values.

Table: Writes a table of raw, and real values into a file, open this file, to verify the expression.

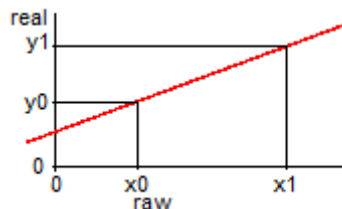

A linear equation

4.5.1 From raw values to Engineering values, Calibration, Output format

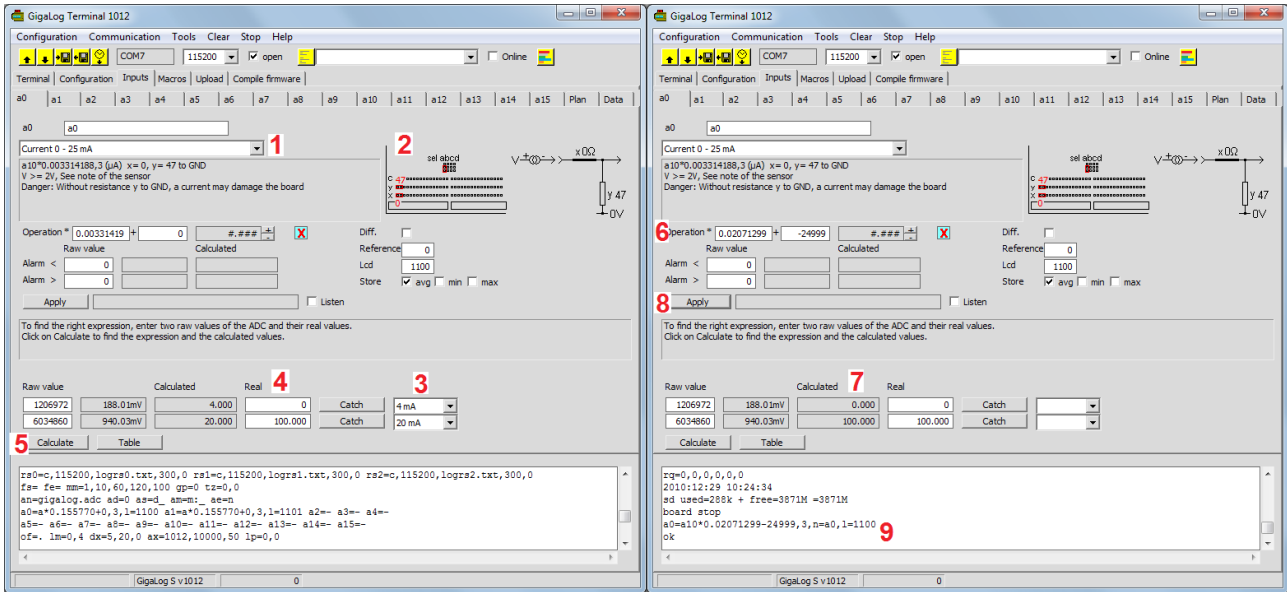

Step by step, how to configure the raw to real expression
 Example a pressure gauge: Output current 4 to 20 mA; 4mA = 0 bar, 20 mA = 100 bar.

1. Select the input type, in the example: Current 0 to 25 mA
 2. Set resistors and jumpers on the board, BEFORE connecting the external signal to the board
- You need two raw values and their correspondent real values to find the linear equation.

You might either

- Enter raw values by hand in the fields Raw values
- Select a value from some proposed tensions or currents, to get the corresponding raw value.
- Apply some pressure, and thereby apply an input voltage, catch these values. This method is directly based on the inputs, the most exact, and also used, to calibrate an input. It is important to catch two raw values, that are not close to each other; in this example two pressures of 0 and 80 bar are better than 0 and 2 bar.

Here we will take the values from the pressure gauge specification.

3. Select 4mA in the first line, to have a raw value.
4. Enter 0 (0 bar) as real value.
3. Select 20mA in the second line
4. Enter 100.000 (100 bar) as real value. The value also describes the output format. A value of 100 will also work.
5. Click on Calculate, to calculate the linear equation.
6. The new operation
7. Verify here, that the new calculated values correspond to the wanted real values.
8. Click on Apply to send the new configuration to the board.
9. The board receives the configuration and responds with OK.

Calibrating a thermocouple: See application notes thermocouple.

Calibrating a Pt100: See application notes Pt100.

4.5.2 Display current values of inputs

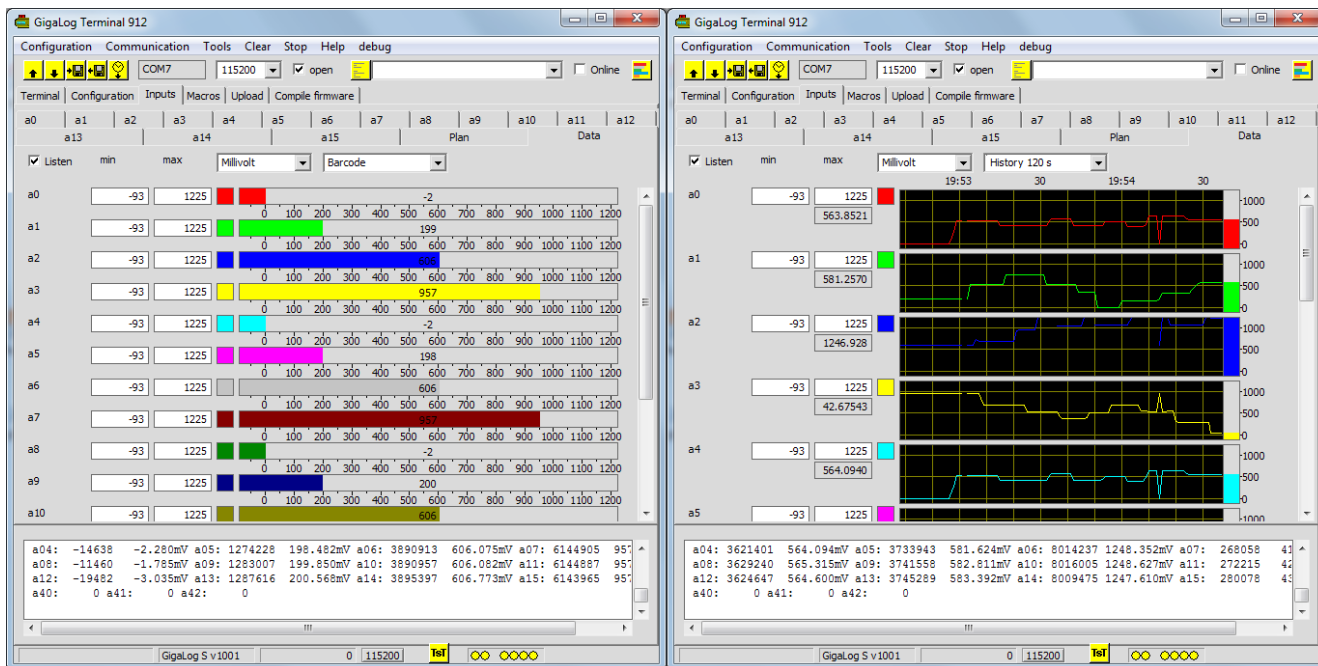

4.6 Macros

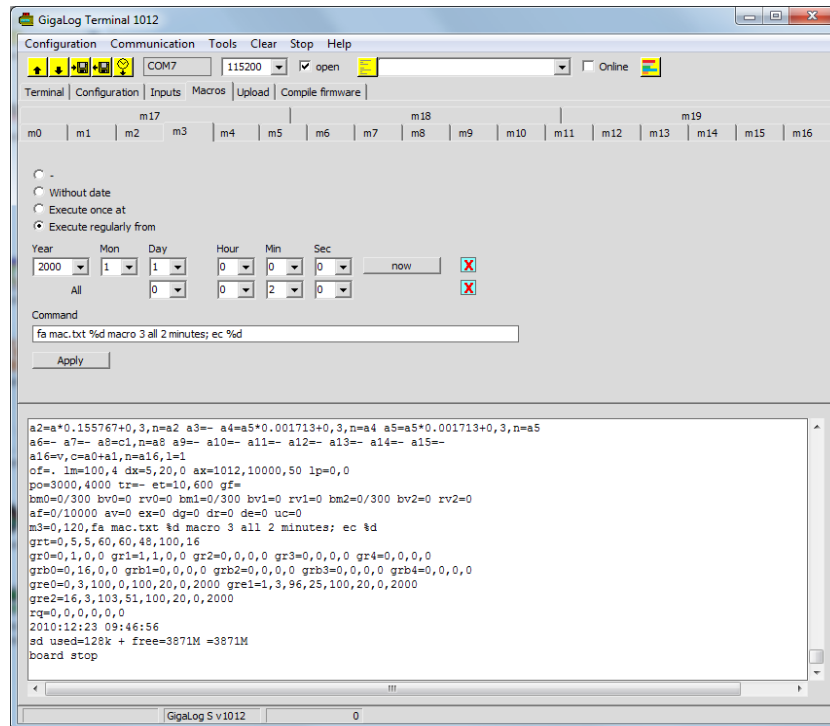

A macro is a sequence of commands, separated by ';' like a command line, entered from the terminal.

A macro can be executed regularly, or under certain conditions. You may load up to 10 macros into the EEPROM of the board.

A macro can

- Write a message to the LCD display
- Write a message into a file on the disk
- Write a message to the rs232 port
- Call a center, and send a message, using a modem.
- Send an SMS, using a GSM modem.
- Toggle a relay on the board.
- Stop sampling, change the configuration, and more

You may define a macro

- Without any date
- To be executed once at a certain time.
- To be executed regularly.
- Starting at a certain time, to be executed regularly.

Some macros will be called under certain conditions:

Macro 0 will be executed after reset, when the board is ready, before the board starts sampling.

Macro 1 will be executed, when an input signals an alarm situation for a certain time (see configuration et)

Macro 1 will be executed again, when the alarm does not disappear within a certain time (see configuration et).

Macro 2 will be executed, when an alarm situation disappears for a certain time (see configuration et)

4.7 Upload

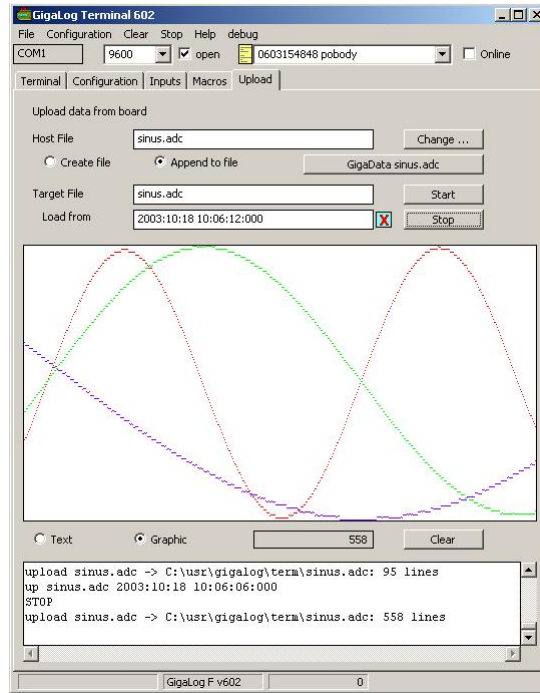

GigaTerm can be used to upload files from the board into a file on the PC: Click on tab Upload. To save a complete file, click on "Create File", and clear the line "Load From". This creates a new file on the PC, or overwrites an existing file, and uploads the complete file from the target board to the PC. When opening an existing file on the PC, GigaTerm will search the last date in the file. To upload only new data, use "Append to File", and "Load from" as last date from the file. This will only look for new data, not yet uploaded, and append them to the existing file on the PC.

When the file is long, the seek of new data and the data transfer can be long. Click on STOP to stop the transfer. The board signals EOF at the end of the file.

When GigaTerm receives a line "up <filename>" from a board, it sets the host file, the target file, selects append to file, and starts uploading the file.

4.8 Firmware Download

GigaTerm can be used to download new firmware into the GigaLog board. You may load the newest firmware from our Internet server. The board must be in configuration mode. Select Tools, Firmware Download.

4.9 First Help

When the firmware does no longer respond, or your configuration does no longer allow you to work. Place a wire from GND to the boot pad on the board beside the battery. Reset the board. The board writes "Download S7" on the port RS0. When you are on USB, enter "dl". Enter "z" to clear the configuration. Download a new firmware. Enter "go" to start the application.

5 GigaData

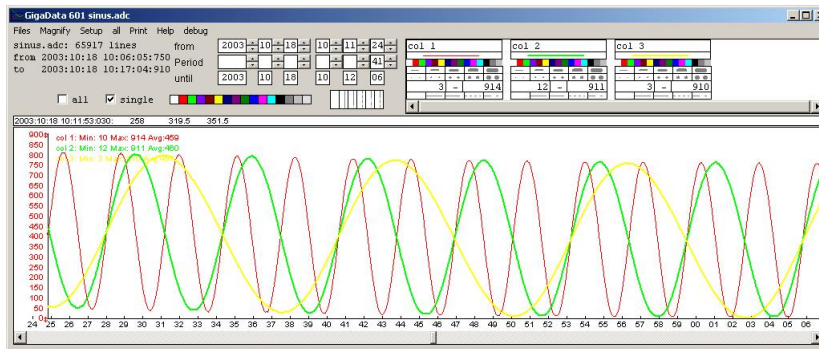

GigaData displays graphically the recorded data. The program has a print setup to fit the data on a page, a print preview, and the print of a data page.

Format of the recorded data

One ASCII line for each record: <date>[t<data>]*

For example 2002:11:09 11:56:30:310 1024 378 567

date may be [<year>:<month>:<day>]<hour>:<minute>[:<second>[:<millisecond>]]

or just <millisecond>: following a line with full date

The day <year>:<month>:<day> may be replaced by <day>/<month>/<year> or <month>/<day>/<year>

Menus

File Menu:

Open Opens a data file.

See ASCII data Open the data file using a text editor to see the original recorded data in ASCII.

Erase data Erases all data in the file.

Erase <filename>.ini Erases all stored display information about this file: column-names, display styles, y-axis.

Magnify

The program works on a buffer of samples covering the whole period. When the file is long, and the chosen period small, this button loads data from the file for a better resolution. The program does this operation automatically, when there is few data on the screen. Printing is always done directly from the data of the file.

Setup: Display or not the data setup.

Print Print the page of data.

Select a period to display

The easiest way: Click and drag the mouse on the x axis in the preview window.

Or select the start of a period. The less important time slots are set to zero. For instance, selecting a day sets hours and minutes to zero, Then select the length of a period.

You can move a period using the horizontal scrollbar of the preview window.

The "All" checkbox indicates that the screen covers the total period. Click on it, to get back the initial period.

You may also use the mouse wheel to zoom data.

Display of data

Data is displayed per column of data in the original file.

Give a name to each data column.

Select a color for the display. A column with a white colour is not displayed.

Select a style of output: line, or points, pen size.

Select the minimum and the maximum value to be displayed on the y axis.

You may also select a scale on displacing the \updownarrow arrows on the y axis.

The symbol  indicates: Reading data from file.

The symbol  indicates: Printing active.

6 Remote Control

Modem GSM/GPRS Telit 863, 864, or 865.

GPRS gives you an access to the Internet. You can directly access the board by TCP/IP. And the board can send data to a server using FTP.

During modem operations data acquisition will continue normally, but the quality may be reduced.

GSM65

This board includes the modem GL865. It mounts directly on the header RS1 on the Gigalog S board. For power supply, see chapter Hardware.

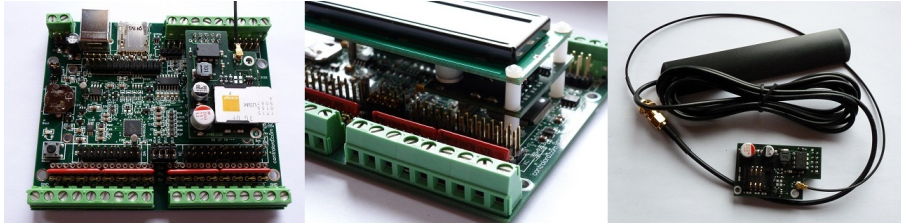

Aarlogic C05/3 (Antrax/ Roundsolutions)

This board includes the modem GE863-GPS

Connection of the board: To Gigalog S by 10 pin flat cable, including power.

Connection of antenna for GSM, and if needed for GPS.

Some changes on the board are needed:

- IDC header 10 pins at X30
- Connection power X30-10 to X2-25 (VIN), image: red.
- Connection autostart X1-7 (On/Off) to X2-9 (GND). Image: yellow.
- Connection GPS signal: X1-16 (RX_TRACE) to X2-12 (TX_GPS_BIN), image: green.

Power supply GigaLog S + Modem: 6-16 V 600 mA.

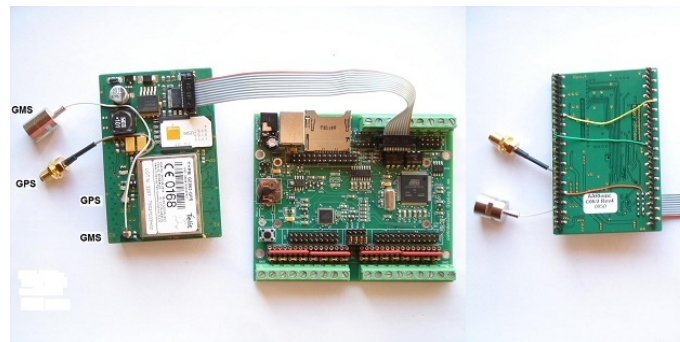

Connecting

Connect the modem to GigaLog S port RS1.

Put a SIM card into the modem.

Use GigaTerm to connect to GigaLog S.

Configuration of RS1

```
rs1=i,115200
```

You need a license of your GSM provider for the GPRS gateway to the Internet. This will also give you: APN Name, APN Userid, APN Password. You may also find these parameters in the Internet. Try at wikipedia.org "Access Point Name"

You also need a server when you want to transfer data by FTP.

FTP IP Adresse like 212.34.67.17, FTP Userid, FTP Password and a directory to store the data.

Configuration of the Modem

Connect to the modem.

tm 1

You are now directly connected to the modem, and can send commands to the modem.

The modem responds with OK on each command. Backspaces in the input line do not work.

at+ipr=115200	Baud Rate
ate	Echo off
ats0=2	Modem responds after 2 rings
at&w	Save these values
at+clk="SC",0,"<PIN code>"	PIN code, ignore error message
at+cgdcont=1,"IP","<APN name>"	Access Point Name
at#userid="<APN userid>"	APN User ID
at#passw="<APN password>"	APN Password
at#sktsav	Save profile

Quit tm mode.

Modem Server

The modem server is a task on GigaLog S, responsible for the communication with the modem.

Most commands concerning the modem are passed to this server.

An OK response only means, that the command was send correctly to the server.

If you want to know the result of the command, enter -v as parameter. Then the server will send a message after having completed the command.

The server starts after reset, when the first parameter of mm is not zero, or the first parameter of gp is non zero. Or it will start by the first command.

The first parameter of mm shall always be 1 or bigger, to have a log file modem.log on the disk.

In case of problems, this parameter allows to log the complete dialogue with the modem on the disk, or to display it on RS0.

The command mm shows the state of the modem.

mm

sim: READY, antenna: 11,0, network: 0,1, context: 1,"IP","internet-entreprise",",",0,0,
IP: 90.100.29.0, port: 1028, man: Telit, mod: GE863-GPS, fw: 07.03.700

Sim, antenna, and network give the state of the GSM network.

There will only be a valid IP number after the gfp command has been executed.

Sending, receiving SMS

Needed: normal SIM card, no GPRS. The modem server must be running, to receive messages.

Send a SMS

sm -v <Number>,<Text>

The text may include special characters: %<n>: Analogue input n, %d: Date and time, %g: GPS position.

The board may receive a command by SMS. For example:

fa sms.txt Hello

Access from outside using a modem

Needed: SIM card with data subscription, no GPRS, a modem on the host side, and a good connection.

The modem server must be running on GigaLog S.

You may use GigaTerm to call the modem and to communicate with the board. Select the serial port of the modem, enter the phone number, click on Online.



Access from outside using GPRS

Needed: SIM card with GPRS, no data. Call gfp before.

The IP number, accorded by the network, must be a public number. This is not obvious. Having a fix IP number is the better solution, but needs a special subscription. If the IP number is not fix, the gfop command can place the number in a file on a server, using FTP. You may use GigaTerm to call the modem and to communicate with the board. Select TCP/IP as serial port, enter the IP number and port 1028, click on Online.

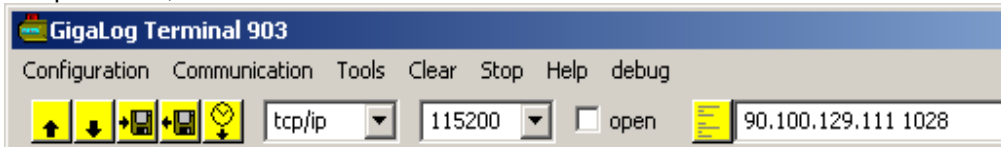

Data transfer to the server by FTP

Needed: SIM card with GPRS, no data.

Commands for the transfer of data by GPRS FTP: Flag -v indicates verbose.

gf=<FTP IP>,<FTP userid>,<FTP password>,<FTP dir>
FTP parameters.

gf
Show own IP number

gfop [-v] [<ServerIPfile>]
Open GPRS context. Open a socket for interactive communication. Store the IP number per FTP in <ServerIPfile> on the server. Gfop is a no op, when the context, and the socket are already open. You may call this command regularly from a macro to re-establish a broken connection. This command is not mandatory for the following commands.

gfput [-v|-b|-c|-d|-t]* <filename> <Serverfilename>
Open a connection as FTP client to a server. Change the directory on the server. Upload a file like in the "up" command in chapter Configuration, Disks, Files. <Serverfilename> is the name of the file on the server. FTP cannot append data to a file. An existing file will be overridden.
-b sends binary data in hexadecimal format.
-c starts reading data at the file offset uc, stores at the end the new file offset in uc.
-d: Append date to the Serverfilename.
-t: Append time to the Serverfilename.

gfcmd [-v|-d|-r]* <Serverfilename>
Load and execute a command line file from the server. The file shall not exceed 2k bytes.
-d: Append date to the Serverfilename.
-r: Remove file on the server after reading.

gftime [-v]
Get date and time from an Internet time server. See chapter GPS, command tz.

gfcl [-v]
Close FTP, close GPRS. This command is not mandatory.

Data transfer will be done by macros

gf	123.45.67.89,myuserid,mypasswd,mysubdir	FTP Parameters
m4	gfop ip.txt; gfput -cdt gigalog.adc gigalog.adc	Open GPRS. Store IP number on the server. Transfer data to the server.

Send the parameters and the macro to GigaLog.
Execute the macro: "mx4".
GigaLog shall now send data to the server.
Finally change the macro 4, so that it will be executed regularly.
And you may open the GPRS after each Reset.

m0	mx3 30	Will be called after Reset, executes macro 3 in 30 seconds.
m3	gfop ip.txt	Open GPRS. Store IP number on the server.

Modem and Low Power

The modem does not have a low power mode.
The commands mmon, and mmoff power the modem on and off.

6.1 GPS

```
gp=<mode><channel>,  
<mode>=      10 GPS activ  
              +20 Set real time clock on the board from GPS time  
              +40 Telit Modem  
gp          Show position and time  
gpgo       Read GPS  
gpti       Set real time clock on the board from GPS time;
```

There are two ways, to connect a GPS

- GPS on a RS232 port, NMEA format
Example: rs0=-,4800 gp=10: GPS 4800 Baud on RS0.
The GPS sends regularly data frames
- Modem with GPS: Telit GE863-GPS
Example: rs1=i,9600 gp=71: The GPS sets the real time clock.
The modem server asks once per minute the GPS position and time

```
tz=<tz offset>,<daylight saving additional offset>
```

The variable tz is only used, when setting the real time clock from the GPS time.

The first value is the time difference in hours to GMT. If this value is > 12, it is in minutes.

The second value is the additional offset for summer time.

Changing to summertime is on the morning of the last Sunday in March, to wintertime on the morning of the last Sunday in October.

Example for European meantime (Paris) tz=1,1. Or tz=60,60.

Setting the real time clock from GPS

The GPS sets the real time clock only

- After a reset of the board, or
- At 1:20 ama, or
- After gpt

The setting will only be done, after having received three consecutive frames with same time information.

Show GPS position: Command gp or ec %g (3.5).

Write GPS position into a file: fa <file> %g (3.4)

Add GPS position to the analogue data file: ae=_gn (3.9)

7 Remote acquisition modules

You may add more inputs to the GigaLog S data logger using Remote Acquisition modules.

These Modules are frequently used in industries, and they come from several suppliers.

Advantech® ADAM-4000, Adlink® NμDAM-6000 ICP® I-7000, eDAM-8000.

Use the RS2 port of the GigaLog S board to create a RS485 network. The GigaLog S is the master of the network.

You may connect up to 9 slaves to GigaLog S.

One or several GigaLog S board can also be connected as slave modules.

GigaLog S handles up to 100 inputs, a0 to a15 are on the board, a16 to a99 are remote.

You may configure for all inputs the expression to calculate the engineering value from the raw value before storing it to the memory card.

All inputs can be displayed on the LCD, and on the optional graphical LCD.

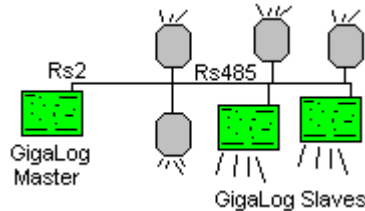

Configuration of a module

Example: Module 9600 baud, Engineering units, with crc

Connect the module to RS2.

Put module to INIT mode Switch power on	In INIT mode, module address is 00, 9600 baud.
rq=0	Stop Remote Acquisition server
rs2=c,9600	RS2 9600 baud
tm 2	Start transparent Mode to RS2
\$002	Send to module, read configuration
!AATTCCFF	Answer of the module
%00NNTTCCFF %0001TT0640	Send new configuration with NN= 01 new ID TT= As read from configuration above CC= 06 for 9600 baud, 0A for 115200 baud. FF= 00 Engineering Unit, no crc FF= 40 Engineering Unit, with crc FF= 02 Hex, no crc FF= 42 Hex, with crc
Switch off INIT. Reset module by switching power off and on.	
<ESC> rs2=c,9600 tm 2,c	Stop transparent mode. Rs2 9600 Baud Start transparent Mode to RS2 with CRC
\$012	Send to module 01, read configuration
!AATTCCFF<crc>	Answer of the module
<ESC>	Stop transparent mode
rq1=16,8	Declare module, Id=01, uses inputs a16 to a23
rq=1,2,1	Start server on RS2, Engineering unit, with crc
d	Show configuration The new inputs will now appear. a16=- a17=- ... a23=- rq=1,2,1 rq1=16,8 GigaTerm: Tab Inputs: New inputs are visible.
rq	Display of dialog statistics with the modules: Successful, error, time out. Should look like this: ok 99 0 0 0 0 0 0 0 0 err 0 0 0 0 0 0 0 0 0 tout 0 0 0 0 0 0 0 0 0
a	Display inputs. A16 to a23 are the inputs on the remote module.

Gigalog S Master with two GigaLog S Slaves

Board 1 (Slave 1): rq=0,0,7,1 rs2=s,115200 a0=a a1=a a15=a	We start with the Slaves. We have to set the slave address on the network and the mode. The board has to accept commands from the network. We have to declare all used inputs.
Board 2 (Slave 2): rq=0,0,7,2 rs2=s,115200 a0=a a1=a a15=a	
Board 0 (Master): rq1=16,16 rq2=32,16 rq=0,2,7,0 d	Now switch to the master. The command d shows 48 inputs.
tm 2 #01 Answer of Slave 1 #02 Answer of Slave 2 <ESC>	Connect now all three boards by the Rs485 2 wire network. Before starting the server, use the tm command to verify the connection to the slaves.
rq=1 rq	Start the server. Display the state.

Log data

st	Stop log
rm gigalog.adc	Erase file
a16=a a17=a	Or using GigaTerm: Configure inputs, apply.
ad=1s	1 sample per second.
go	Start log.
	Wait some seconds
st	Stop log
up gigalog.adc	Display stored data.

Configuration

rq=<on>, <serial port>, <data mode>, <slave id>, <gaptime>, <moduletimeout>
Starts or stops the Remote Acquisition Server, who polls the modules for new data.
You must configure the RS232 port before, using the rs command.

<data mode>:

Mode	crc	Master	Slave
0	-	Decimal	Decimal 16 bit. The board send the raw value divided by 256. 1V has a raw value of 25077.
1	+	Discarding decimal point	
2	-	Hex 4 digits	Hex 16 bit. The board send the raw value divided by 256. 1V has a raw value of 25077.
3	+		
4	-	Like mode 0/1	Decimal. The board sends the raw value.
5	+		
6	-	Like mode 0/1	Decimal. The board sends the real value.
7	+		

Calculating from raw to real value can be done by the slave (in data mode 6/7) or by the master (in data mode 4/5).

<slave id> 01.. (in decimal !)

<gaptime> time in milliseconds between two requests to the modules. This time can be 0.

<moduletimeout> time in milliseconds, when the server treats a request as not responded.
When tis time is 0, it will be set to 1000 (1s).

rq<module>=<input0>,<inputs>

Configuration of a module. modules can be from 1 to 9.

Inputs of the modules will be mapped to the inputs a<input0> to a<input0+inputs>.

rqz

Zero statistic counters

GigaLog S as Remote Acquisition Slave

Gigalog S recognizes the command "#<nn>" on all serial ports.

When the id <nn> is not the own slave id, GigaLog S will not respond.

When the id <nn> is the own slave id, GigaLog S answers with the data of all configured channels.

Internals

The Remote Acquisition Server only send the "#AA" command to the modules and expects the answer in hexadecimal, 4 characters signed, or in the form [+|-]12.345.

At 115200 baud GigaLog S can send about 200 requests per second to the modules.

8 Graphic Display

A graphic display can be connected to GigaLog S. The display replaces the alpha numeric display. Ampire AM320240 320 x 240 Pixel, 5.7 inch. Colour, Technology TFT, Backlight, Touch panel.

Connection and power supply

Power supply: See chapter Hardware.

Connection by flat cable to the IDC header LCD.

Configuration:

"Im=100" for graphic LCD.

"Im=101" graphic LCD, the first channels display simulated data.

All configuration values, including those entered by the touch screen, like the parameters to display a channel, can also be entered by a serial input or USB, and are part of the normal configuration.

Page Bar graph

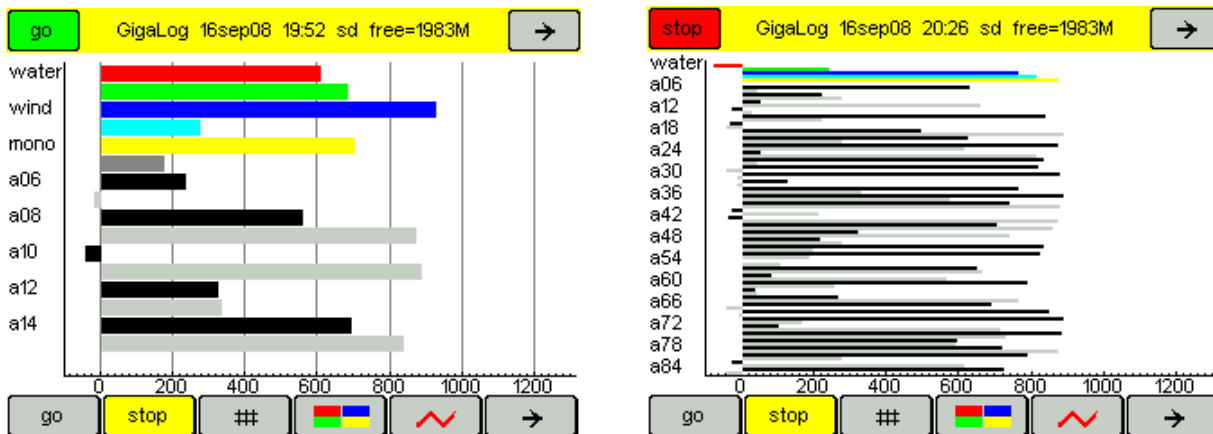

Show internal and external up to 100 inputs as bar graphs in real time.

You may declare up to 5 bar graph pages.

Choose the inputs to display in the configuration.

Min and Max determine the mapping of the data on the x axe.

When both are zero, or Min >= Max, raw values will be shown in millivolt.

Otherwise the LCD shows engineer values.

Page Log Data

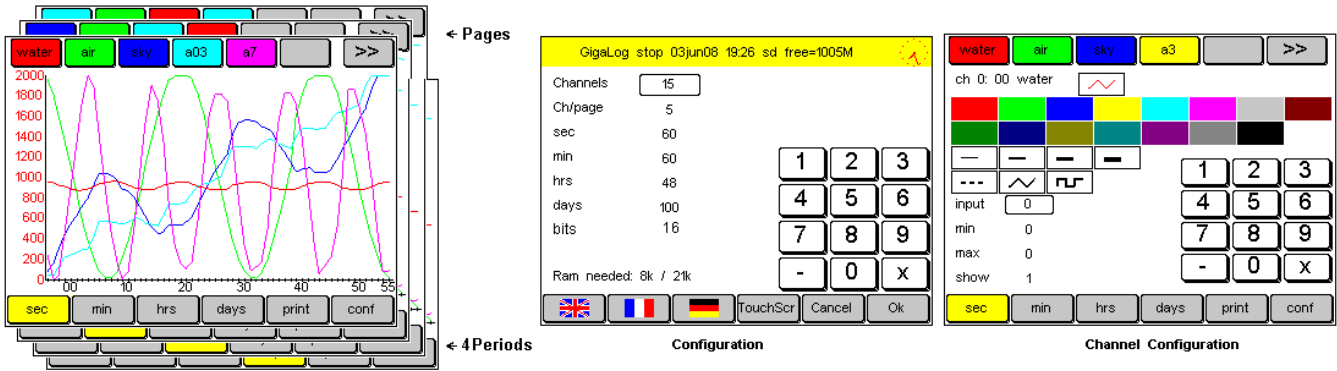

The display shows 15 channels on 3 pages, 5 channels per page.
It shows

- The last 60 seconds, or
- The last 60 minutes, or
- The last 48 hours, or
- The last 100 days.

You may change the number of channels, channels per page, and the length of each period.

The data for the display is stored independent of the data logged on the memory card.

The data for the display will be lost when power is switched off.

The data for a minute is calculated from the last 60 seconds. If there are less than 60 seconds, the minute is calculated from the existing data. If there are more than 60 seconds, they will be ignored.

Data for an hour are calculated from the last 60 minutes, and for a day from the last 24 hours in the same way.

Upper menu

The upper menu displays a state line or the channels of the page.

The menu toggles automatically after some seconds to the state line.

Channels are not equal to inputs. You may assign any input to a channel.

The button of a channel is in its colour, and displays its name.

Clicking on the button of a channel brings the channel into the foreground and its y-axis is displayed.

Clicking on -> changes the page and displays other channels.

Bottom menu

You may select on the bottom menu the period to display

-> Advance the menu

Toggles the grid on or off

Print Store the picture on the screen into a Bitmap file on the memory card.

Configuration of a Channel

Double click on its button in the top menu line.

Select its colour, width, and style. Select an input.

Min and Max determine the appearance of the function on the screen.

Do not mistake with the min and max of an input to trigger an alarm.

When these values are zero, the appearance will be calculated from the data.

Show: display the channel, on or off.

Select a field, and enter the value using the keyboard.

Name, colour, and style belong to the configuration of the input, and can be changed using GigaTerm.

Configuration of the graphic

Click on "conf" in the bottom menu line.

You may change the number of channels, channels per page, and the length of each period.

The number of bits per value: 16, 24, or 32 bits.

Be careful with the RAM needed. The displayed needed RAM must not turn to red.

Change the language.

Adjust the touch panel.

Page Scope

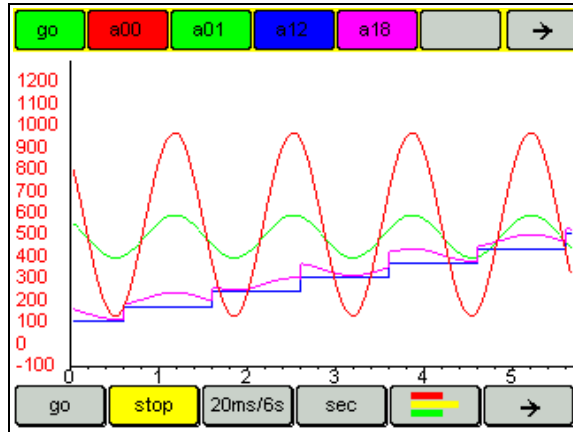

Similar to logged data page. You reach this page by the log data page, click on the "ms" button.

Mode	Sampling	On screen
Scope Inputs are displayed as sampled. Stop stops sampling at the end of the display. Click on Stop again for a one shot on the display.	1 ms	.3 s
	2 ms	.6 s
	5 ms	1.5 s
	10 ms	3 s
	20 ms	6 s
	50 ms	15 s
	100 ms	30 s
	200 ms	60 s
	500 ms	150 s
Log Data stored in volatile RAM. Average data over sample period. Log length configurable.	1 s	90 s
	1 m	60 m
	1 h	48 h
	1 d	100 d

Display of 5 channels per page (configurable)

5 pages of data (configurable)

Display of data on the LCD is completely independent of the data logging to the memory card.

Page Installation

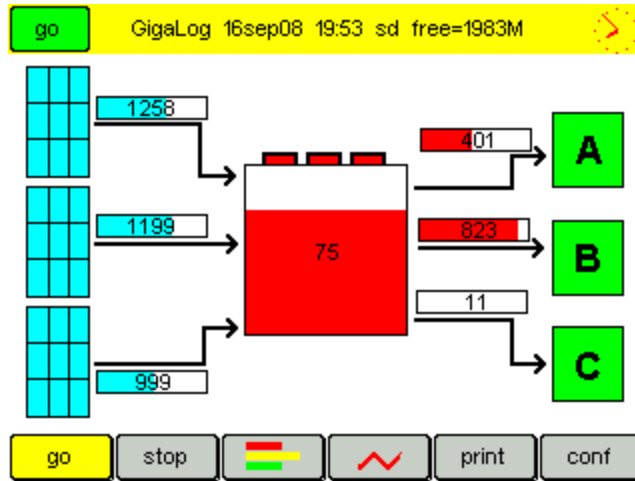

Show an installation with inputs in bar graphs.

Example of a photovoltaic system: Three panels with their charge current in bar graphs. The charge state of the batteries. Three consumers currents.

Installation background image

When there is a file "machina.bmp" on the memory card, the display takes this file as background image. Display from a file is slow and only useful for demonstration and test. If the file does not exist, it takes "machina.bmp" from Flash memory. To change this file, you have to rebuild the firmware. Machina.bmp is a 16 colours Bitmap file. Maximal size: width: 320 pixels, height: 180 pixels. When the Flash image is not bigger than 160 x 90 pixels, it will be doubled in size. A 320 x 180 pixel image in Flash memory costs 29 k, a 160 x 90 pixel image only 7 k. The resolution is lower, but normally sufficient.

Installation bar graphs

The bar graphs in the foreground display the actual state of the analogue inputs.

Click and drag a bar graph to displace it.

Click on a bar graph to change its configuration.

Choose an input and a style. Style 0 will not be displayed.

Position on the LCD, width and height.

Min and Max determine the mapping of the data as on a bar graph page.

Page Command terminal

On the terminal page, You can enter commands as on a Rs232 or USB terminal.

```
gre2=2,5,118,51,84,90,0,1000 gre3=3,3,46,158,50,12,0,2000
gre4=4,3,200,151,50,12,0,2000
rq=0,0,0,0,0,0
2008:12:16 09:55:49
sd used=4256k + free=3867M =3871M
board stop
ls
gigalog.adc          4248996 13dec08 10:42:04
ok
grp image.bmp
ok
```

1	2	3	4	5	6	7	8	9	0	=	bs	
a	b	c	d	e	f	g	h	i	j	k	l	m
n	o	p	q	r	s	t	u	v	w	x	y	z
%	.	,	;	+	-	*				cmd	end	

Configuration, Commands

9 Application Notes

9.1 Memory cards, File lengths, Transfer to the PC

Analogue data are sampled into a text file, each sample in a line.
A typical line looks like this:

```
2006:11:30 14:07:50 5120,45 33333 1289,00 123456
```

This line includes date, time, and the data of four channels.
It has a length of 48 characters and occupies together with the line end 50 bytes in the file.
Let's take a 2 Giga byte memory card, you can store

$$2.000.000.000 / 50 = 40.000.000$$

40 million samples on the card. With a sample rate of 1 second, the card can store data as long as 462 days.
The calculation in details for a 1 second sample rate.

Total memory card 2.000.000.000	/ characters per line / 50	= Max. samples per card 40.000.000 samples
Samples per memory card 40.000.000	/ 60	= sample time in minutes 666.666 minutes
Sample time in minutes 666.666	/ 60	= sample time in hours 11.111 hours
Sample time in hours 11.111	/ 24	= sample time in days 462 days

Note, that the real sample rate is higher than the selected sample rate. GigaLog stores the average sum of the last period in the disk file.
See analogue data, Sample rates.
Very often a slower sample rate is sufficient.

Milliseconds

When the sample rate is faster than 1 second, normally only the millisecond will be stored instead of the whole date time.
This takes less place in the file.

Example for a 50 ms rate:

```
2006:11:30 14:07:50:000 5120,45 33333 1289,00 123456
050: 5120,45 33333 1289,00 123456
100: 5120,45 33333 1289,00 123456
150: 5120,45 33333 1289,00 123456
```

Transfer of data to the PC.

Data can be uploaded with GigaTerm to the PC using the serial interface. Since this is slow, huge data shall be transferred using a memory card reader on the PC. The data is stored in a file on the memory card.

Reading the data on the PC

Data can be read by

- GigaData, shows the data graphically.
- Text editor, like Blocknotes, Word, Write, etc
- Spreadsheet, like Ex*el

Other data formats

Configuration fields as, am, ae determine the format of the stored data
See Configuration, Analogue inputs, Frames. Default values are

as	Frame start	d_	Date: yyyy:mm:dd hh:mm[:ss[:uuu]]<tab>
am	Frame start, millisecond	m_	millisecond <tab>
ae	Frame end	n	carriage return new line<cr><nl>

9.2 Tuning the ADC

The ADC is an independent unit, that scans automatically and cyclic all inputs by a multiplexer, converts the input to a digital value and informs the microprocessor, that a new result is available. The firmware reads out the digital value of the input. During this time, the ADC already converts the next channel.

If you declare an analogue channel as z or as v, for example a15=z, it will not participate in sampling, and the sample rate will increase for the other channels. The following table is based on the use of all 16 channels. You may also declare the partner of a differential channel as z, for example a8=a,d=1; a9=z.

Reasons to change the configuration of the ADC

- Increase the resolution
- Increase the speed for fast analogue data, faster than 100 Hz
- Increase the speed for fast counter inputs

Configuration values				Measured values				
ax	Chop	Delay	Drate	Sps	Sps/16	% cpu	Analogue Inputs resolution	Counter max
1021	1	2	1	2760	172	10	+1 bit	82 Hz
* 1012	1	1	2	6630	414	25	0	200 Hz
1013	1	1	3	9800	613	37	-0.5 bit	290 Hz
0003	0	0	3	23350	1460	87	-1.5 bit	700 Hz

Configuration values:

Ax

Value of the configuration for the analogue to digital conversion: <chop><bias><delay><drate>.

The value 1012 is the default value.

Chop (0..1)

When chop is 1, the adc converts the + and - inputs as wanted, and does then a second conversion with the opposite polarity.

Chop=1 reduces the offset error.

Delay (0..7)

Time after switching the multiplexer to another input, before starting the conversion.

Some time is needed to have a stable input.

Drate (0..3)

The ADC executes several consecutive conversions on an input and calculates the average sum.

A small value indicates many conversions.

Drate corresponds to a digital low pass filter.

Increasing drate reduces the filter but gives more results to the firmware. The firmware also calculates the average sum by another digital filter.

Measured values:

Sps, Sps/16

Samples per seconds, is the number of probes in a second.

Sps/16 is Sps divided by 16, and the number of probes in a second for each input.

% Cpu

Usage of the microprocessor for reading the ADC.

Analogue Inputs resolution

Increasing or decreasing of the resolution relative to the default value.

Counter max

When using the input as a counter, the maximal allowed frequency is Sps/16 divided by 2.

For example: Ax=1012, the default value, Sps/16 is 414. The maximal allowed frequency is 200 Hz;

the signal must be stable for 2.5 ms for each level, 0 and 1.

The command xxa gives information about the ADC.

Reference: Texas Instruments: Ads1258 datasheet Rev. E Oct. 2007.

9.3 Calculation from the analogue input raw value

Calculation from analogue input raw values of the ADC to real values, or engineer values by a linear equation are handled in

- Hardware, From raw values to Engineering values, calibration
- Configuration, Analogue inputs a<ch>=
- GigaTerm, Inputs. From raw values to Engineering values

Reference input

When an input is in relation to another input, you can subtract the reference input with p=<ch>. The subtraction will be done on the real values of both inputs.

Example: Heating: A1= outgoing water temperature, a2, a3,... back coming water temperature of several cycles. The board samples the outgoing temperature, and the temperature difference for each cycle.
A1=t; a2=t,p=1; a3=t,p=1 ...

See Configuration, Analogue inputs a<ch>=[,p=<reference>]
Do not confuse with differential mode.

9.3.1 Virtual input, calculation

Declaration of a virtual input, calculated from other inputs by an expression.

Expression is a sequence of up to 5 elements, connected by +,-,*, or /.

Elements are inputs or small constants (0..99).

Example: c=a0-a1*a2

Calculation will be done on the calculated real values of the inputs, strictly from left to right.

The value of a counter is the count of the last full period, as defined by ad.

You may select any analogue input a0..a15 for a virtual input, the analogues input will then be lost.

You may also select any input from a16 or higher as virtual input.

The result of the calculation can then be recalculated by *m+p,c into another unit or output format.

A16=v*100,2 does not change the result, but the output format in the file and on the display.

Example heat pump:

A1= temperature incoming water, a2= temperature outgoing water, a3= water flow.

Calculation of the power: (a2-a1)*a3: A16=v,c=a2-a1*a3

Use *m+p,c to convert the result into watt.

See Configuration, Analogue inputs a<ch>=v

A virtual input can not trigger an alarm.

A virtual input may use other virtual inputs as parameters. Calculation is done from a0 to a99 without recursion.

9.3.2 Long time counter

A long time counter adds values of a long period.

When switching power off, no data, or only data of the last seconds will be lost.

Long time counters use the same syntax as virtual inputs, with a<ch>=vc instead of a<ch>=v

Example: Tachometer, one pulse per revolution; ad=1m

A7=c stores the current speed in revolutions per minute.

A16=vc,c=a7 counts all revolutions.

Example: Heat pump as above.

Calculation of the energy (a2-a1)*a3: A17=vc,c=a2-a1*a3; Or A17=vc,c=a16

Use *m+p,c to convert the result into watt hours.

A16 stores the current power in watt.

A17 stores the complete energy in watt hours since the begin of sampling.

Long time counters are saved each minute on the memory card in the file counts.txt and counts2.txt. The firmware also stores the counters when switching from Go to Stop mode. There is no counting in Stop mode.

After Reset the firmware reads the counters from the files.

The av command changes the counters
av= z clears all counters
av<ch>= <n> sets a single counter.
av<ch>+= <n> increments a single counter.

See Configuration, Analogue inputs a<ch>=vc

Time counter

a20=vc
m4=0,60,av20+=1

The long time counter A20 is not connected to any input.
The macro m4 increments the counter each minute.
A20 counts the operating hours based on minutes.

9.4 Second Disk

You may connect a second disk to the board, either a Sd-card or an USB key.

Connecting a sd-card.

Header XC
1 GND
4 3V3
5 SDSEL
6 Card Detect
13 SCLK
14 MOSI
15 MISO

Set the 3. parameter of dx to 4.

To connect a USB key, you need a Vdrive2 from FTDI.

Connecting Vdrive2

Header XC	Vdrive2
1 GND	1
5 SDSEL	6
13 SCLK	5
14 MOSI	4
15 MISO	2
2 5V	3

Select per jumper: SPI mode

Set the 3. parameter of dx to 6.

The USB key can not replace the sd-card on the board.

The USB key is about 10 times slower than the sd card.

The command `xxdk` displays information about all connected disk drives.

The address of the 2. disk is d:

For example:

`ls d:`

`cd d:`

`cp abc.txt d:abc.txt`

9.5 Temperature Sensor LM60

The LM60 is an integrated circuit in TO92 housing.

It senses temperatures from -40°C to $+125^{\circ}\text{C}$.

The LM60 output voltage is linear to the measured temperature, thus easy to connect to a GigaLog board.

The expression, to calculate temperature from the input voltage, is

$a0 = a * 0.610352 - 6784,2$. Resolution $0,01^{\circ}\text{C}$

9.6 Thermocouples

You can directly connect a thermocouple type K to an analogue input of the board. A thermocouple type K measures temperatures up to 1300 °C. A thermocouple outputs a very small voltage, the signal is very sensitive to noise. The thermocouple voltage is relative to the board temperature. Some cold junction compensation is needed, to find the absolute temperature. This is done by the firmware on the board.

You should calibrate a thermocouple input. Calibration applies a linear equation to the result, thereby slightly moving it.

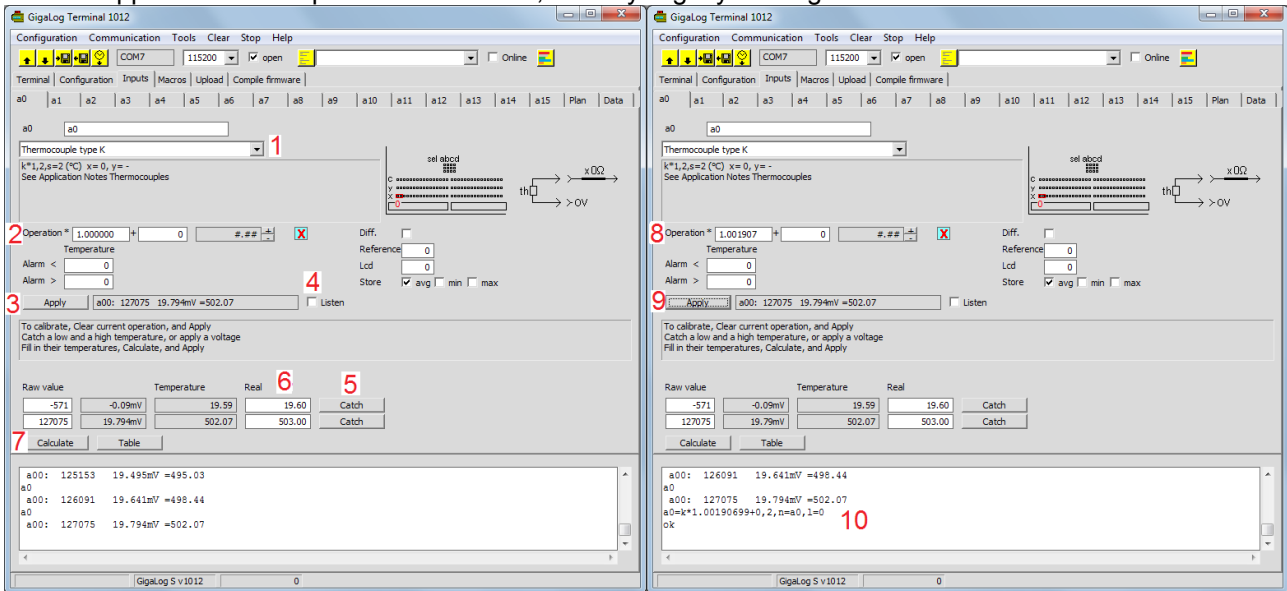

Open GigaTerm, tab Inputs, open the input.

1. Select or reselect thermocouple
2. Verify that you have the original operation: *1+0 #.##
3. Click on Apply to send this configuration to the board
4. Click on Listen to visualize the board temperature
5. Catch a low temperature in the 1. line, for instance the surrounding temperature
6. Enter the wanted temperature with two digits: 19.60
5. Catch a high temperature in the 2. line. Take a temperature as high as possible.
6. Enter the wanted temperature with two digits: 503.00
7. Click on Calculate to calculate the linear equation
8. The new operation. The multiplier of the operation shall be close to 1, else there is an error.
9. Click on Apply to send the new configuration to the board
10. The board receives the configuration and responds with OK.

You may also simulate a temperature, by applying a voltage to the input, and fetching the temperature from a table. You have to add the board temperature, and insert the sum as the wanted temperature.

Thermocouple K mV -> °C

mV	+ 0	+ 0.1	+ 0.2	+ 0.3	+ 0.4	+ 0.5	+ 0.6	+ 0.7	+ 0.8	+ 0.9
0	0.00000	2.50890	5.01798	7.52603	10.0320	12.5350	15.0342	17.5292	20.0193	22.5042
1	24.9836	27.4575	29.9255	32.3879	34.8445	37.2955	39.7411	42.1815	44.6168	47.0475
2	49.4738	51.8961	54.3146	56.7299	59.1422	61.5519	63.9594	66.3652	68.7696	71.1730
3	73.5758	75.9783	78.3809	80.7839	83.1878	85.5927	87.9989	90.4068	92.8167	95.2287
4	97.6431	100.060	102.480	104.902	107.328	109.757	112.189	114.625	117.063	119.506
5	121.952	124.401	126.854	129.310	131.770	134.233	136.699	139.169	141.642	144.117
6	146.596	149.077	151.561	154.047	156.536	159.027	161.519	164.014	166.510	169.007
7	171.506	174.006	176.506	179.008	181.510	184.012	186.514	189.017	191.519	194.020
8	196.522	199.022	201.522	204.020	206.518	209.014	211.508	214.001	216.493	218.982
9	221.470	223.955	226.439	228.920	231.399	233.876	236.350	238.822	241.291	243.758
10	246.222	248.684	251.143	253.599	256.053	258.504	260.953	263.399	265.842	268.284
11	270.722	273.158	275.592	278.023	280.452	282.879	285.303	287.726	290.146	292.564
12	294.980	297.395	299.807	302.218	304.627	307.034	309.440	311.844	314.247	316.649
13	319.049	321.447	323.845	326.241	328.636	331.030	333.423	335.815	338.206	340.596
14	342.986	345.374	347.761	350.148	352.533	354.918	357.302	359.686	362.068	364.450
15	366.830	369.210	371.590	373.968	376.346	378.722	381.098	383.473	385.847	388.220
16	390.593	392.964	395.335	397.704	400.073	402.440	404.807	407.173	409.538	411.902
17	414.265	416.627	418.988	421.348	423.707	426.066	428.424	430.781	433.137	435.493
18	437.848	440.202	442.556	444.910	447.263	449.615	451.968	454.320	456.671	459.023
19	461.375	463.726	466.077	468.429	470.780	473.131	475.482	477.832	480.183	482.533
20	484.882	487.230	489.578	491.924	494.269	496.611	498.952	501.295	503.639	505.971
21	508.323	510.674	513.024	515.374	517.724	520.073	522.421	524.769	527.117	529.464
22	531.811	534.158	536.504	538.850	541.197	543.542	545.888	548.234	550.580	552.925
23	555.271	557.617	559.962	562.308	564.654	567.000	569.347	571.693	574.040	576.387
24	578.734	581.082	583.430	585.778	588.127	590.476	592.825	595.175	597.525	599.876
25	602.228	604.580	606.932	609.285	611.639	613.993	616.348	618.703	621.060	623.416
26	625.774	628.132	630.491	632.851	635.212	637.573	639.935	642.298	644.662	647.026
27	649.392	651.758	654.126	656.494	658.863	661.233	663.604	665.976	668.348	670.722
28	673.097	675.473	677.850	680.228	682.607	684.986	687.368	689.750	692.133	694.517
29	696.902	699.289	701.676	704.065	706.455	708.846	711.238	713.631	716.025	718.421
30	720.818	723.216	725.615	728.015	730.417	732.820	735.224	737.629	740.035	742.443
31	744.852	747.262	749.674	752.087	754.501	756.916	759.333	761.751	764.170	766.590
32	769.012	771.435	773.860	776.286	778.713	781.141	783.571	786.002	788.435	790.868
33	793.304	795.740	798.178	800.617	803.058	805.5	807.944	810.388	812.835	815.282
34	817.731	820.182	822.634	825.087	827.542	829.998	832.455	834.914	837.375	839.836
35	842.300	844.764	847.231	849.698	852.167	854.638	857.110	859.583	862.058	864.535
36	867.013	869.492	871.973	874.455	876.939	879.425	881.912	884.400	886.890	889.382
37	891.875	894.369	896.865	899.363	901.862	904.363	906.865	909.369	911.875	914.382
38	916.890	919.401	921.912	924.426	926.941	929.457	931.976	934.495	937.017	939.540
39	942.065	944.591	947.119	949.649	952.180	954.713	957.248	959.785	962.323	964.862
40	967.404	969.947	972.492	975.039	977.587	980.137	982.689	985.243	987.799	990.356
41	992.915	995.476	998.038	1000.60	1003.17	1005.74	1008.31	1010.88	1013.45	1016.03
42	1018.61	1021.18	1023.77	1026.35	1028.93	1031.52	1034.11	1036.70	1039.29	1041.89
43	1044.49	1047.08	1049.69	1052.29	1054.89	1057.50	1060.11	1062.72	1065.33	1067.95
44	1070.57	1073.19	1075.81	1078.43	1081.06	1083.69	1086.32	1088.95	1091.58	1094.22
45	1096.86	1099.50	1102.14	1104.79	1107.44	1110.09	1112.74	1115.40	1118.06	1120.72
46	1123.38	1126.04	1128.71	1131.38	1134.05	1136.73	1139.41	1142.09	1144.77	1147.45
47	1150.14	1152.83	1155.52	1158.22	1160.92	1163.62	1166.32	1169.03	1171.74	1174.45
48	1177.16	1179.88	1182.60	1185.32	1188.05	1190.78	1193.51	1196.24	1198.98	1201.72
49	1204.46	1207.21	1209.96	1212.71	1215.47	1218.23	1220.99	1223.75	1226.52	1229.29
50	1232.07	1234.84	1237.62	1240.41	1243.20	1245.99	1248.78	1251.58	1254.38	1257.18
51	1259.99	1262.80	1265.62	1268.43	1271.26	1274.08	1276.91	1279.74	1282.58	1285.42
52	1288.26	1291.11	1293.96	1296.81	1299.67	1302.54	1305.40	1308.27	1311.15	1314.02
53	1316.91	1319.79	1322.68	1325.58	1328.47	1331.38	1334.28	1337.19	1340.11	1343.03
54	1345.95	1348.88	1351.81	1354.75	1357.69	1360.63	1363.58	1366.54	1369.49	1372.53

9.7 Pt100, Pt1000

Pt100 measure temperatures from -200°C to $+850^{\circ}\text{C}$. The Pt100 is a resistance that changes with the temperature. To transform this resistance into a voltage at the input of a GigaLog board, you need a 1k Ohm pull up resistor to 5V. The result is a non linear function, that the firmware converts into temperature (0.1°C).

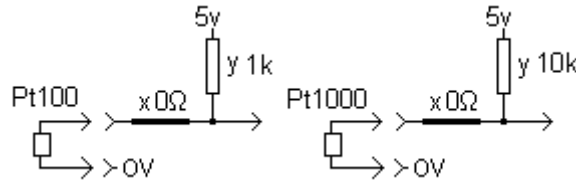

The wires from the sensor to the board should be as short as possible, since they also has a resistance.

Use a 0.1 resistance as pull up resistor y.

There are 2-wire, 3-wire, and 4-wire sensors. Here we use only two of them.

You should calibrate the Pt100 input. Calibration applies a linear equation to the result, thereby slightly moving it.

Open GigaTerm, tab Inputs, open the input.

1. Select or reselect Pt100.
2. Verify the resistors and jumpers.
3. Verify that you have the original operation: $*1+0 \#\#$
4. Click on Apply to send this configuration to the board
5. Click on Listen to visualize the board temperature
6. Catch in the 1. line a low temperature, as low as possible.
7. Enter the wanted temperature with 1 digit: 11.2
6. Catch in the 2.line a high temperature. Take a temperature as high as possible.
7. Enter the wanted temperature with 1 digit: 73.2
8. Click on Calculate to calculate the linear equation
9. The new operation. The multiplier of the operation shall be close to 1, else there is an error.
10. Click on Apply to send the new configuration to the board
11. The board receives the configuration and responds with OK.

You may also simulate a temperature, by applying a resistance to the input, and fetching the temperature from a table.

	+0	+1	+2	+3	+4	+5	+6	+7	+8	+9
-200	18.493	18.926	19.358	19.790	20.221	20.653	21.083	21.514	21.944	22.374
-190	22.803	23.232	23.661	24.089	24.517	24.945	25.372	25.799	26.226	26.652
-180	27.078	27.504	27.929	28.354	28.779	29.203	29.627	30.051	30.474	30.897
-170	31.320	31.742	32.165	32.587	33.008	33.429	33.850	34.271	34.691	35.111
-160	35.531	35.951	36.370	36.789	37.208	37.626	38.044	38.462	38.879	39.297
-150	39.714	40.130	40.547	40.963	41.379	41.795	42.210	42.625	43.040	43.455
-140	43.869	44.283	44.697	45.111	45.524	45.937	46.350	46.763	47.175	47.587
-130	47.999	48.411	48.822	49.234	49.645	50.055	50.466	50.876	51.286	51.696
-120	52.106	52.515	52.924	53.333	53.742	54.151	54.559	54.967	55.375	55.783
-110	56.190	56.598	57.005	57.412	57.818	58.225	58.631	59.037	59.443	59.849
-100	60.254	60.659	61.065	61.469	61.874	62.279	62.683	63.087	63.491	63.895
-90	64.299	64.702	65.105	65.508	65.911	66.314	66.717	67.119	67.521	67.923
-80	68.325	68.727	69.128	69.530	69.931	70.332	70.733	71.134	71.534	71.934
-70	72.335	72.735	73.135	73.534	73.934	74.333	74.733	75.132	75.531	75.930
-60	76.328	76.727	77.125	77.523	77.921	78.319	78.717	79.115	79.512	79.910
-50	80.307	80.704	81.101	81.498	81.894	82.291	82.687	83.083	83.479	83.875
-40	84.271	84.667	85.063	85.458	85.853	86.248	86.643	87.038	87.433	87.828
-30	88.222	88.617	89.011	89.405	89.799	90.193	90.587	90.980	91.374	91.767
-20	92.160	92.553	92.946	93.339	93.732	94.125	94.517	94.910	95.302	95.694
-10	96.086	96.478	96.870	97.262	97.653	98.045	98.436	98.827	99.218	99.609
0	100.000	100.391	100.781	101.172	101.562	101.953	102.343	102.733	103.123	103.513
10	103.902	104.681	105.461	106.241	107.021	107.801	108.581	109.361	110.141	110.921
20	107.793	108.181	108.570	108.958	109.346	109.734	110.122	110.510	110.897	111.284
30	111.672	112.059	112.446	112.833	113.220	113.607	113.994	114.380	114.767	115.153
40	115.539	115.925	116.311	116.697	117.083	117.469	117.854	118.240	118.625	119.010
50	119.395	119.780	120.165	120.550	120.934	121.319	121.703	122.087	122.471	122.855
60	123.239	123.623	124.007	124.390	124.774	125.157	125.540	125.923	126.306	126.689
70	127.072	127.454	127.837	128.219	128.602	128.984	129.366	129.748	130.130	130.511
80	130.893	131.274	131.656	132.037	132.418	132.799	133.180	133.561	133.941	134.322
90	134.702	135.083	135.463	135.843	136.223	136.603	136.982	137.362	137.741	138.121
100	138.500	138.879	139.258	139.637	140.016	140.395	140.773	141.152	141.530	141.908
110	142.286	142.664	143.042	143.420	143.797	144.175	144.552	144.930	145.307	145.684
120	146.061	146.438	146.814	147.191	147.567	147.944	148.320	148.696	149.072	149.448
130	149.824	150.199	150.575	150.950	151.326	151.701	152.076	152.451	152.826	153.201
140	153.575	153.950	154.324	154.698	155.072	155.446	155.820	156.194	156.568	156.941
150	157.315	157.688	158.061	158.435	158.808	159.180	159.553	159.926	160.298	160.671
160	161.043	161.415	161.787	162.159	162.531	162.903	163.274	163.646	164.017	164.388
170	164.760	165.131	165.501	165.872	166.243	166.614	166.984	167.354	167.724	168.095
180	168.465	168.834	169.204	169.574	169.943	170.313	170.682	171.051	171.420	171.789
190	172.158	172.527	172.895	173.264	173.632	174.000	174.368	174.736	175.104	175.472
200	175.840	176.207	176.575	176.942	177.309	177.676	178.043	178.410	178.777	179.143
210	179.510	179.876	180.242	180.609	180.975	181.340	181.706	182.072	182.438	182.803
220	183.168	183.534	183.899	184.264	184.628	184.993	185.358	185.722	186.087	186.451
230	186.815	187.179	187.543	187.907	188.271	188.634	188.998	189.361	189.724	190.088
240	190.451	190.813	191.176	191.539	191.901	192.264	192.626	192.988	193.350	193.712
250	194.074	194.436	194.798	195.159	195.521	195.882	196.243	196.604	196.965	197.326
260	197.686	198.047	198.407	198.768	199.128	199.488	199.848	200.208	200.568	200.927
270	201.287	201.646	202.006	202.365	202.724	203.083	203.442	203.800	204.159	204.517
280	204.876	205.234	205.592	205.950	206.308	206.666	207.024	207.381	207.739	208.096
290	208.453	208.810	209.167	209.524	209.881	210.237	210.594	210.950	211.307	211.663
300	212.019	212.375	212.731	213.086	213.442	213.797	214.153	214.508	214.863	215.218
310	215.573	215.928	216.282	216.637	216.991	217.346	217.700	218.054	218.408	218.762
320	219.115	219.469	219.823	220.176	220.529	220.882	221.235	221.588	221.941	222.294
330	222.846	223.199	223.551	223.903	224.255	224.607	224.959	225.311	225.663	226.014
340	226.168	226.517	226.868	227.219	227.570	227.921	228.272	228.622	228.973	229.323
350	229.673	230.023	230.373	230.723	231.073	231.423	231.772	232.122	232.471	232.820
360	233.169	233.518	233.867	234.216	234.565	234.913	235.261	235.610	235.958	236.306
370	236.654	237.002	237.349	237.697	238.044	238.392	238.739	239.086	239.433	239.780
380	240.127	240.473	240.820	241.166	241.513	241.859	242.205	242.551	242.897	243.242
390	243.588	243.934	244.279	244.624	244.969	245.314	245.659	246.004	246.349	246.693
400	247.038	247.382	247.726	248.070	248.414	248.758	249.102	249.446	249.789	250.132
410	250.476	250.819	251.162	251.505	251.848	252.190	252.533	252.875	253.218	253.560
420	253.902	254.244	254.586	254.928	255.270	255.611	255.953	256.294	256.635	256.976
430	257.317	257.658	257.999	258.339	258.680	259.020	259.360	259.701	260.041	260.381
440	260.720	261.060	261.400	261.739	262.078	262.418	262.757	263.096	263.435	263.773
450	264.112	264.450	264.789	265.127	265.465	265.803	266.141	266.479	266.817	267.155
460	267.492	267.829	268.167	268.504	268.841	269.178	269.514	269.851	270.188	270.524
470	270.860	271.197	271.533	271.869	272.205	272.540	272.876	273.211	273.547	273.882
480	274.217	274.552	274.887	275.222	275.557	275.891	276.226	276.560	276.894	277.228
490	277.562	277.896	278.230	278.564	278.897	279.231	279.564	279.897	280.230	280.563
500	280.896	281.229	281.561	281.894	282.226	282.559	282.891	283.223	283.555	283.886
510	284.218	284.550	284.881	285.212	285.544	285.875	286.206	286.537	286.867	287.198
520	287.529	287.859	288.189	288.519	288.849	289.179	289.509	289.839	290.169	290.498
530	290.827	291.157	291.486	291.815	292.144	292.472	292.801	293.130	293.458	293.786
540	294.115	294.443	294.771	295.098	295.426	295.754	296.081	296.409	296.736	297.063
550	297.390	297.717	298.044	298.371	298.697	299.024	299.350	299.676	300.002	300.328
560	300.654	300.980	301.306	301.631	301.957	302.282	302.607	302.932	303.257	303.582
570	303.907	304.231	304.556	304.880	305.204	305.528	305.852	306.176	306.500	306.824
580	307.147	307.471	307.794	308.117	308.440	308.763	309.086	309.409	309.732	310.054
590	310.377	310.699	311.021	311.343	311.665	311.987	312.309	312.630	312.952	313.273
600	313.594	313.915	314.236	314.557	314.878	315.199	315.519	315.840	316.160	316.480
610	316.800	317.120	317.440	317.760	318.079	318.399	318.718	319.037	319.357	319.676
620	319.995	320.313	320.632	320.951	321.269	321.587	321.906	322.224	322.542	322.860
630	323.177	323.495	323.812	324.130	324.447	324.764	325.081	325.398	325.715	326.032
640	326.348	326.665	326.981	327.298	327.614	327.930	328.246	328.561	328.877	329.193
650	329.508	329.823	330.139	330.454	330.769	331.083	331.398	331.713	332.027	332.342
660	332.656	332.970	333.284	333.598	333.912	334.226	334.539	334.853	335.166	335.479
670	335.792	336.105	336.418	336.731	337.044	337.356	337.669	337.981	338.293	338.605
680	338.917	339.229	339.541	339.852	340.164	340.475	340.786	341.098	341.409	341.720
690	342.030	342.341	342.652	342.962	343.272	343.583	343.893	344.203	344.512	344.822
700	345.132	345.441	345.751	346.060	346.369	346.678	346.987	347.296	347.605	347.913
710	348.222	348.530	348.838	349.147	349.455	349.762	350.070	350.378	350.685	350.993
720	351.300	351.607	351.914	352.221	352.528	352.835	353.142	353.448	353.754	354.061
730	354.367	354.673	354.979	355.285						

10 Technical Summary

Power supply Board with alphanumerical LCD 2x16, typ Low power mode, typ Board with graphic LCD, typ	75 ma @ 6-16 V < 1 mA 400 mA @ 12V
Analogue Inputs	
Impedance all inputs used only one input used, others set to a<n>=z	> 10 M Ohm > 2 M Ohm
Input range total max measured	-0.1 to 5V -100 to 1300 mV
ADC Resolution Measured average resolution at storage rate < 10ms > 10ms, < 100 ms > 100 ms	24 bits signed 16 bits 18 bits 19 bits
Reference voltage ADC	1225 mV ± 1.2 mV @ 25°C; ± 10 mV @ 0..70°C
Conversion ADC -> voltage voltage -> ADC	$U = \text{ADC} * 1225 / 0x780000 = \text{ADC} * 0.1557668 \mu\text{V}$ $\text{ADC} = U(\text{mV}) * 6419.85$
Digital inputs A0 to A15 Logical 0 Logical 1 XC Logical 0 Logical 1	0 to 0.8 V 1.2V to 5V 0 to 0.8 V 2V to 5V
Real time clock error typ max	5 ppm (3 min/y) @ 25°C + 0.05 ppm/°C 20 ppm (10 min/y) @ 25°C + 0.05 ppm/°C
Relays output	100mA 250 V
Environmental temperature Operating Storage	-10 .. +50°C -20 .. +70°C
Mechanical length x width x height, weight Board only Board with mounted alphanumeric LCD 2x16 Din housing with board Graphic LCD Board+ graphic LCD in housing	101 86 15 mm, 75 g 101 86 25 mm, 105 g 106 91 80 mm, 220 g 167 108 37 mm, 260 g 200 122 58 mm, 630 g

ADC: Texas Instrument ADS1258 in delta-sigma technology.

Voltage reference: LM4041-AIM3-1.2.

Battery cr1220 3V Lithium, only used for real time clock and counters (bm...).

The configuration is stored in the internal Flash memory of the microcontroller.

11 Components placement

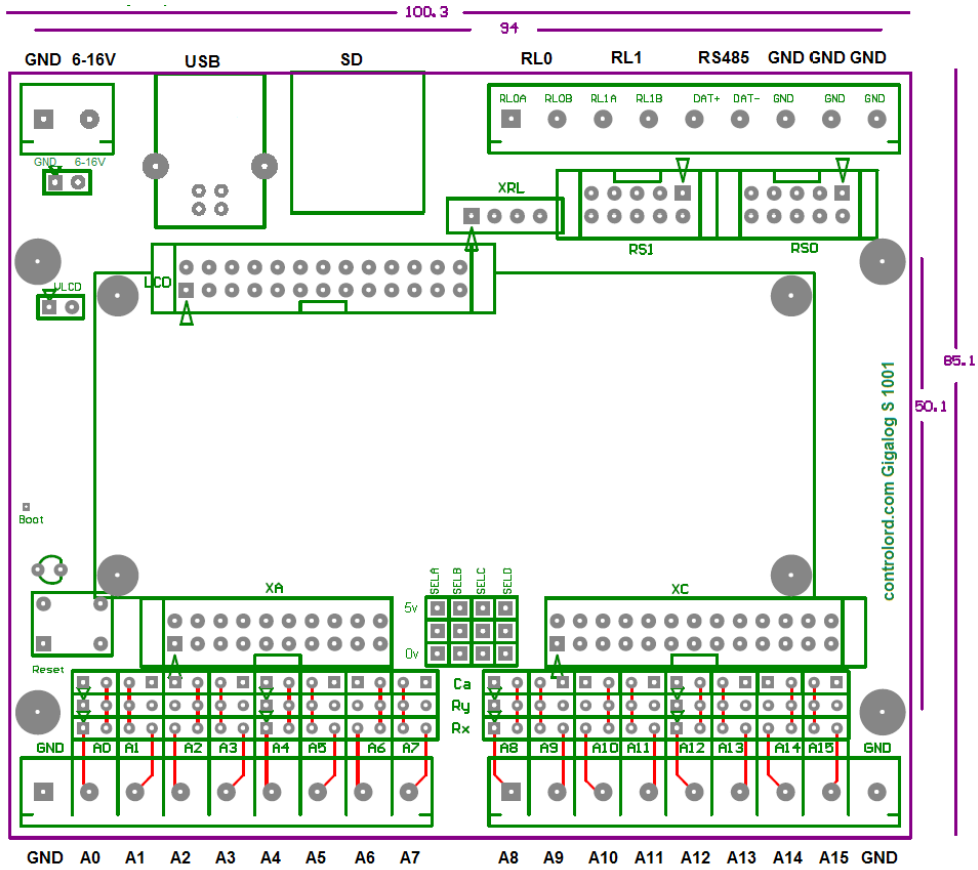

12 Schematics

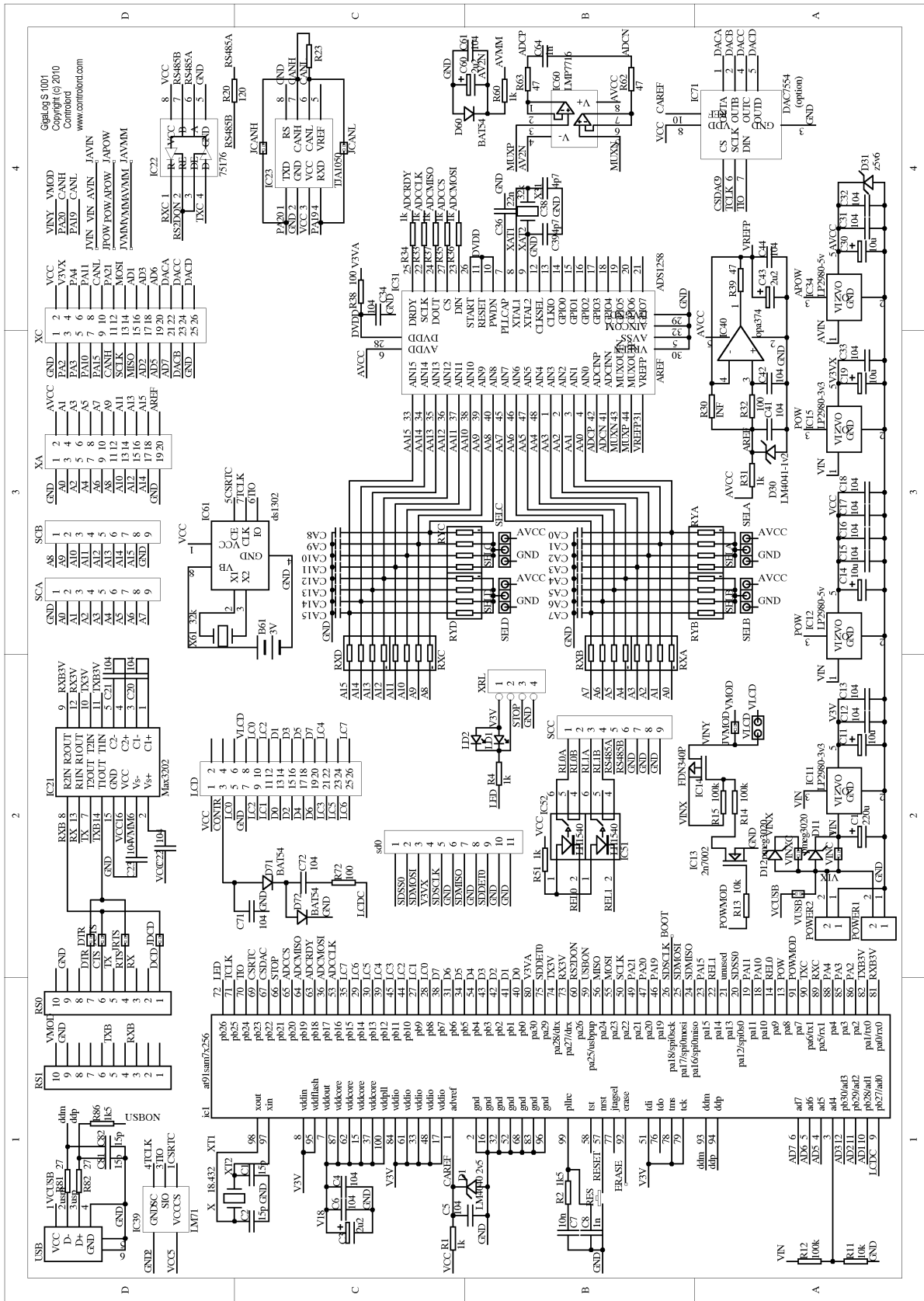

13 Older Hardware: Gigalog S 805

Hardware 805 differs from this manual in the following points:

Power supply: plug 1.3 mm, positive voltage in the centre. Lumberg NES/J 135, Cliff DCPP3

Non existing commands: mmon, mmoff, gron, groff

Remote control, Aarlogic C05/3: RS1 pin 10 is not connected. Connect to power supply.